

**Canon**

**SPEEDLITE 380EX**

**C50-0721**

**PARTS  
CATALOG**

# CANON SPEEDLITE 380 EX

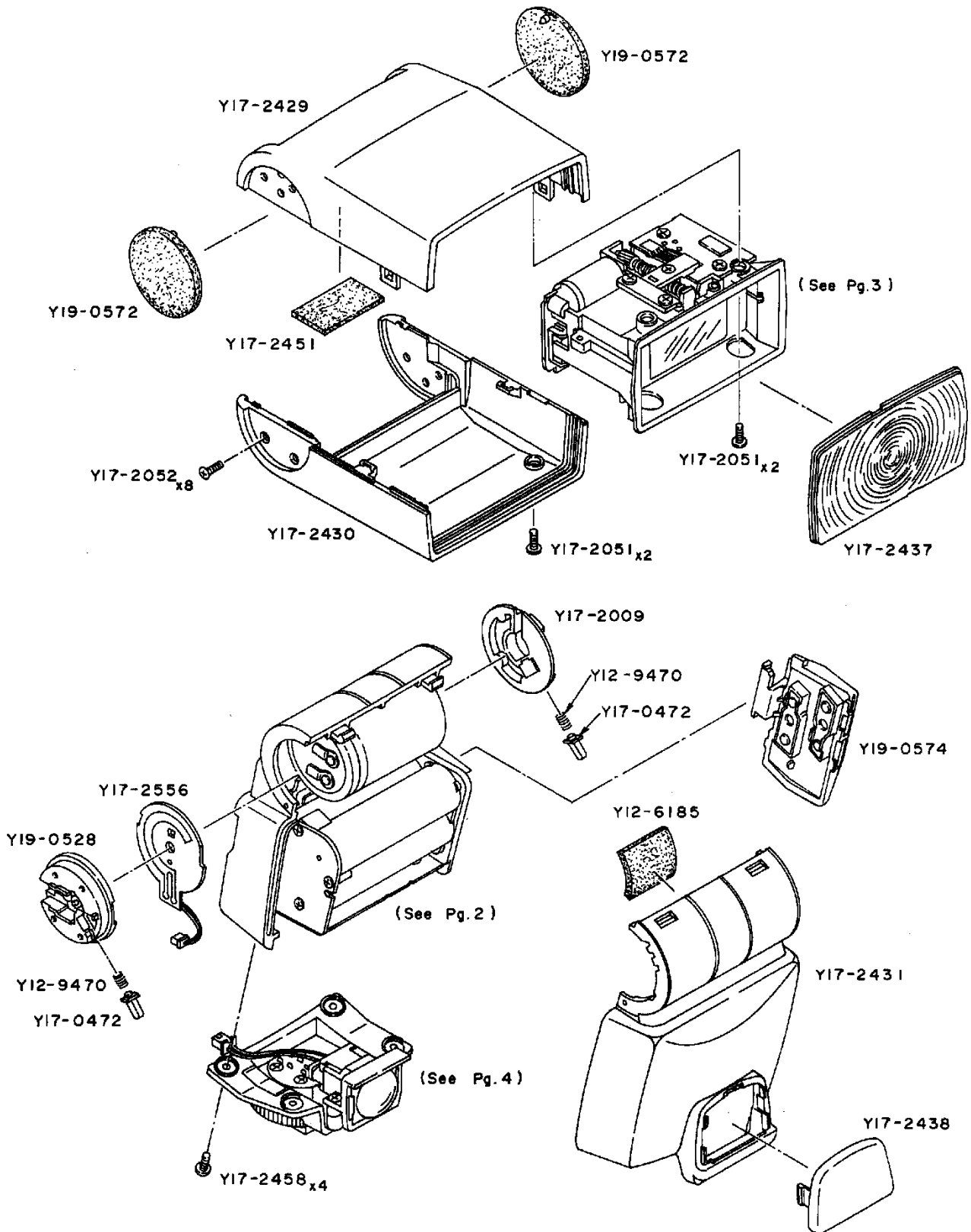

# PARTS LIST

REF.NO.C50-0721

Report.No.NEW	PARTS NO.	CLASS	QTY	DESCRIPTION
	Y12-6185-000	E	1	SPACER
	Y12-9470-000	E	2	SPRING, COIL
	Y17-0472-000	E	2	PIN, CLICK
	Y17-2009-000	E	1	WHEEL, PIVOT(R)
	Y17-2051-000		4	SCREW
	Y17-2052-000		8	SCREW
	Y17-2429-000	D	1	COVER, TOP
	Y17-2430-000	D	1	COVER, BOTTOM
	Y17-2431-000	D	1	COVER, FRONT
	Y17-2437-000	D	1	PANEL, FRESNEL
	Y17-2438-000	D	1	PANEL, AF LED
	Y17-2451-000	E	1	SPACER
	Y17-2458-000		4	SCREW
	Y17-2556-000	E	1	PCB(F)
	Y19-0528-000	D	1	WHEEL, PIVOT(L)
	Y19-0572-000	D	2	COVER, RUBBER
	Y19-0574-000	D	1	COVER ASS'Y, BATTERY

# CANON SPEEDLITE 380EX

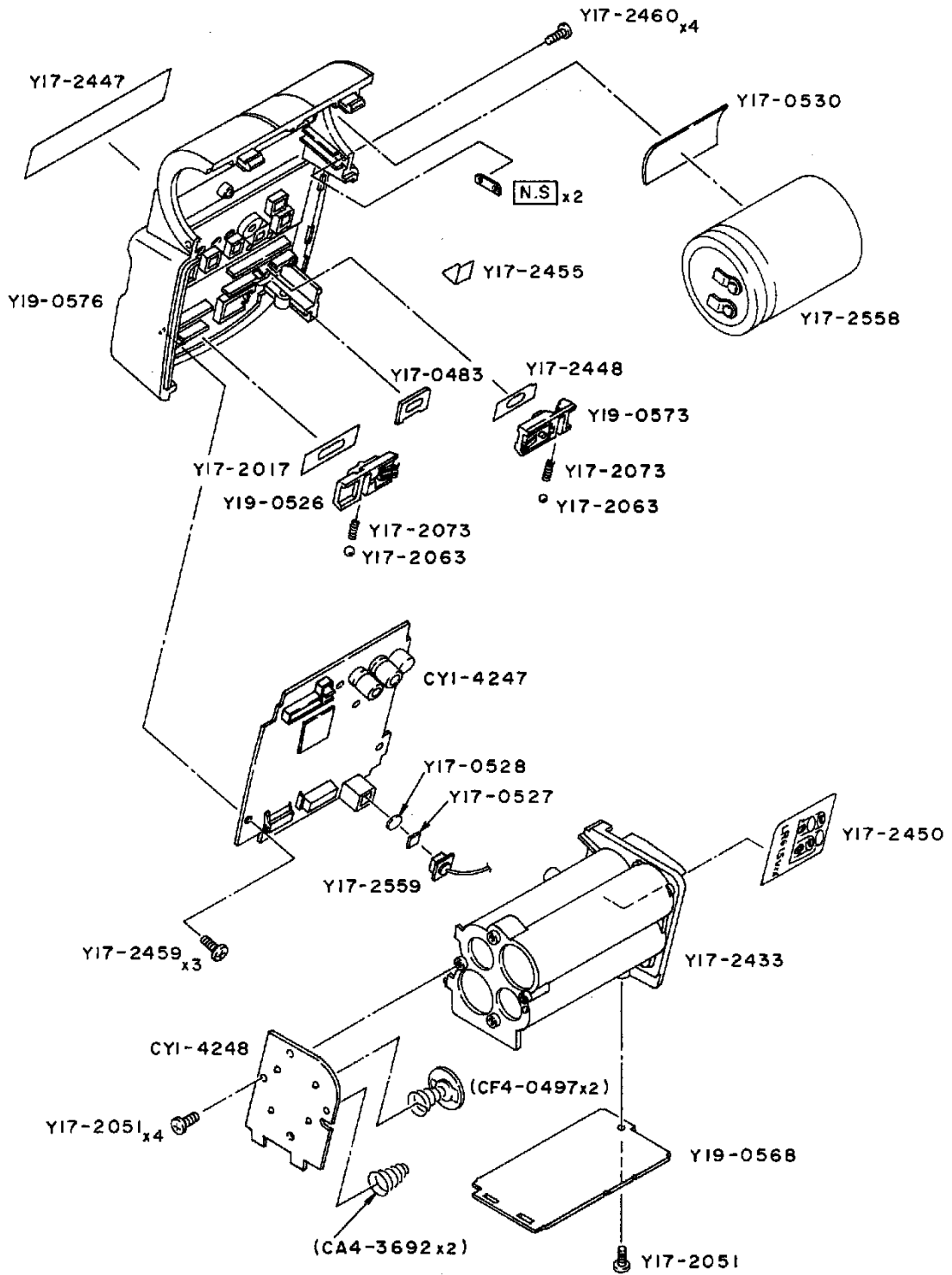

# PARTS LIST

REF.NO.C50-0721

Report.No.NEW	PARTS NO.	CLASS	QTY	DESCRIPTION
	CA4-3692-000	D	2	CONTACT, BATTERY
	CF4-0497-000	C	2	CONTACT, ASS'Y, BATTERY
	CY1-4247-000	D	1	PCB ASS'Y(A)
	CY1-4248-000	D	1	PCB ASS'Y(C)
	Y17-0483-000	D	1	BUTTON, TEST
	Y17-0527-000	D	1	FILTER
	Y17-0528-000	D	1	FILTER, ND
	Y17-0530-000	E	1	TAPE, DOUBLE-SIDED
	Y17-2017-000	D	1	PLATE, MAIN SWITCH
	Y17-2051-000		5	SCREW
	Y17-2063-000	D	2	BALL
	Y17-2073-000	E	2	SPRING, COIL
	Y17-2433-000	E	1	CASE, BATTERY
	Y17-2447-000	D	1	PLATE, REAR
	Y17-2448-000	E	1	PLATE, CONTROL SWITCH
	Y17-2450-000	E	1	STICKER, BATTERY
	Y17-2455-000	E	1	INSULATOR
	Y17-2459-000		3	SCREW
	Y17-2460-000		4	SCREW
	Y17-2558-000	D	1	CAPACITOR, AL-EL MAIN
	Y17-2559-000	D	1	CONNECTOR, OPTICAL
	Y19-0526-000	D	1	SWITCH ASS'Y, MAIN
	Y19-0568-000	D	1	PCB ASS'Y(B)
	Y19-0573-000	D	1	SWITCH ASS'Y, CONTROL
	Y19-0576-000	D	1	COVER ASS'Y, REAR

# CANON SPEEDLITE 380EX

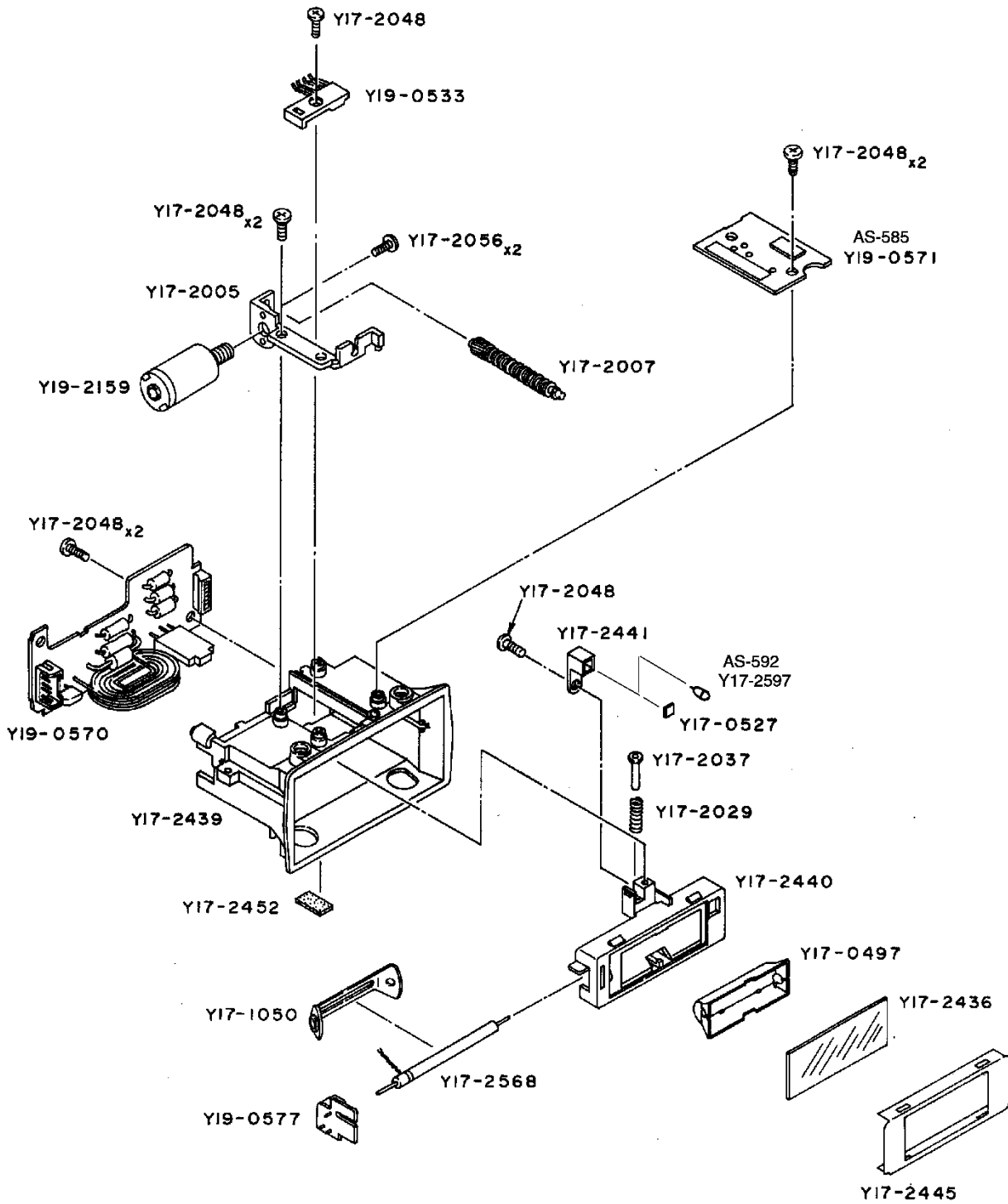

# PARTS LIST

REF.NO.C50-0721

Report.No.	NEW	PARTS NO.	CLASS	QTY	DESCRIPTION
		Y17-0497-000	E	1	REFLECTOR, MAIN
		Y17-0527-000	D	1	FILTER
		Y17-1050-000	E	1	BUSH, MOUNTING
		Y17-2005-000	E	1	HOLDER, ZOOM MOTOR
		Y17-2007-000	E	1	SHAFT, ZOOM
		Y17-2029-000	E	1	SPRING, COIL
		Y17-2037-000	E	1	PIN, ZOOM
		Y17-2048-000		8	SCREW
		Y17-2056-000		2	SCREW
		Y17-2159-000	D	1	MOTOR, ZOOM
		Y17-2436-000	D	1	PANEL, FRONT
		Y17-2439-000	E	1	HOUSING, XENON LAMP
		Y17-2440-000	D	1	FRAME, MAIN LAMP
		Y17-2441-000	E	1	CASE, SENSOR
		Y17-2445-000	E	1	HOLDER, PANEL
		Y17-2452-000	E	1	CUSHION
		Y17-2568-000	D	1	LAMP, XENON
AS-592		Y17-2597-000	D	1	PHOTO DIODE
		Y19-0533-000	D	1	SWITCH ASS'Y, ZOOM
		Y19-0570-000	D	1	PCB ASS'Y(D)
AS-585		Y19-0571-000	D	1	PCB ASS'Y(E)
		Y19-0577-000	D	1	PCB ASS'Y(G)

# CANON SPEEDLITE 380EX

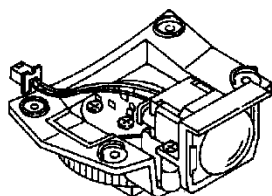

N.S

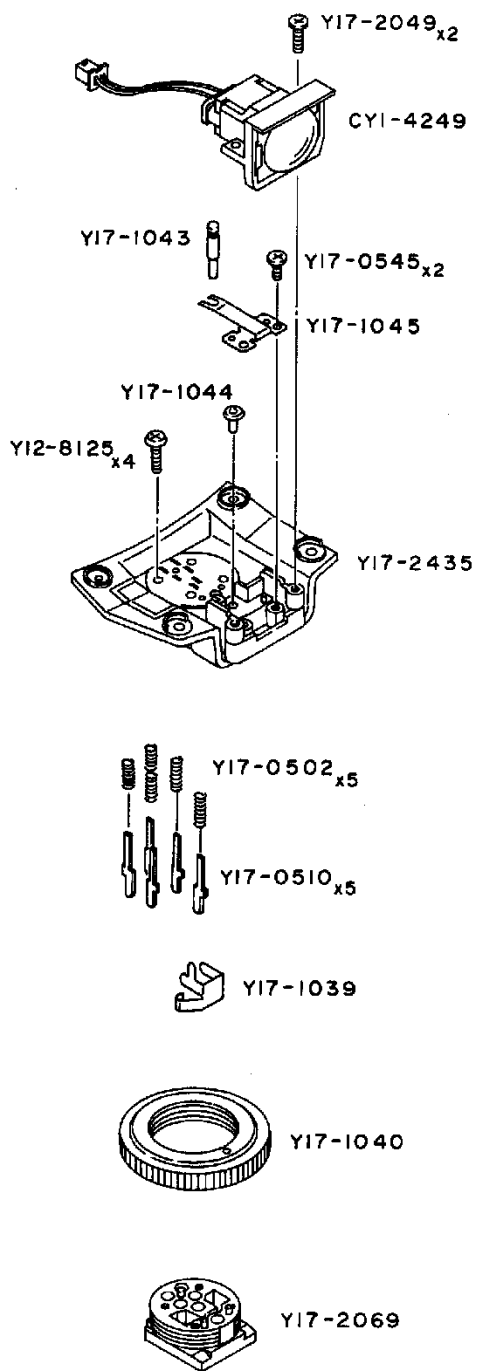



# PARTS LIST

REF.NO.C50-0721

Report.No.NEW	PARTS NO.	CLASS	QTY	DESCRIPTION
	CY1-4249-000	D	1	LED UNIT, AF
	Y12-8125-000		4	SCREW
	Y17-0502-000	D	5	SPRING, COIL
	Y17-0510-000	D	5	CONTACT, SHOE
	Y17-0545-000		2	SCREW
	Y17-1039-000	D	1	CONTACT, SHOE(-)
	Y17-1040-000	D	1	NUT, SHOE
	Y17-1043-000	D	1	PIN, SHOE LOCK
	Y17-1044-000	D	1	PIN, LOCK
	Y17-1045-000	D	1	CONTACT, SHOE LOCK
	Y17-2049-000		2	SCREW
	Y17-2069-000	C	1	SHOE
	Y17-2435-000	D	1	CASE, SHOE

# ELECTRIC PARTS LIST

REF.NO.C50-0721-000

REPORT NO.	PARTS NO.	CLASS	QTY	DESCRIPTION
AS-586	WA3-6458-000		1	EEPROM
	Y17-2560-000		1	LEAD ASS'Y CN-1
	Y17-2561-000		1	LEAD ASS'Y CN-2
	Y17-2562-000		1	LEAD ASS'Y CN-3
	Y17-2563-000		1	LEAD ASS'Y CN-4
	Y17-2564-000		1	LEAD ASS'Y CN-5
	Y17-2565-000		1	LEAD ASS'Y CN-6
	Y17-2566-000		1	LEAD ASS'Y CN-7
	Y17-2567-000		1	LEAD ASS'Y CN-8