



EOS-1Ds

REF.NO.C12-6021

CANON Ni-MH PACK NP-E3 C50-8041,2

CANON NECK STRAP L4 C56-1731

CANON INTERFACE CABLE C50-8081

IFC-450D6

CANON DC COUPLER KIT C50-8051

DCK-E1

PARTS CATALOG

CANON DIGITAL CAMERA EOS-1Ds

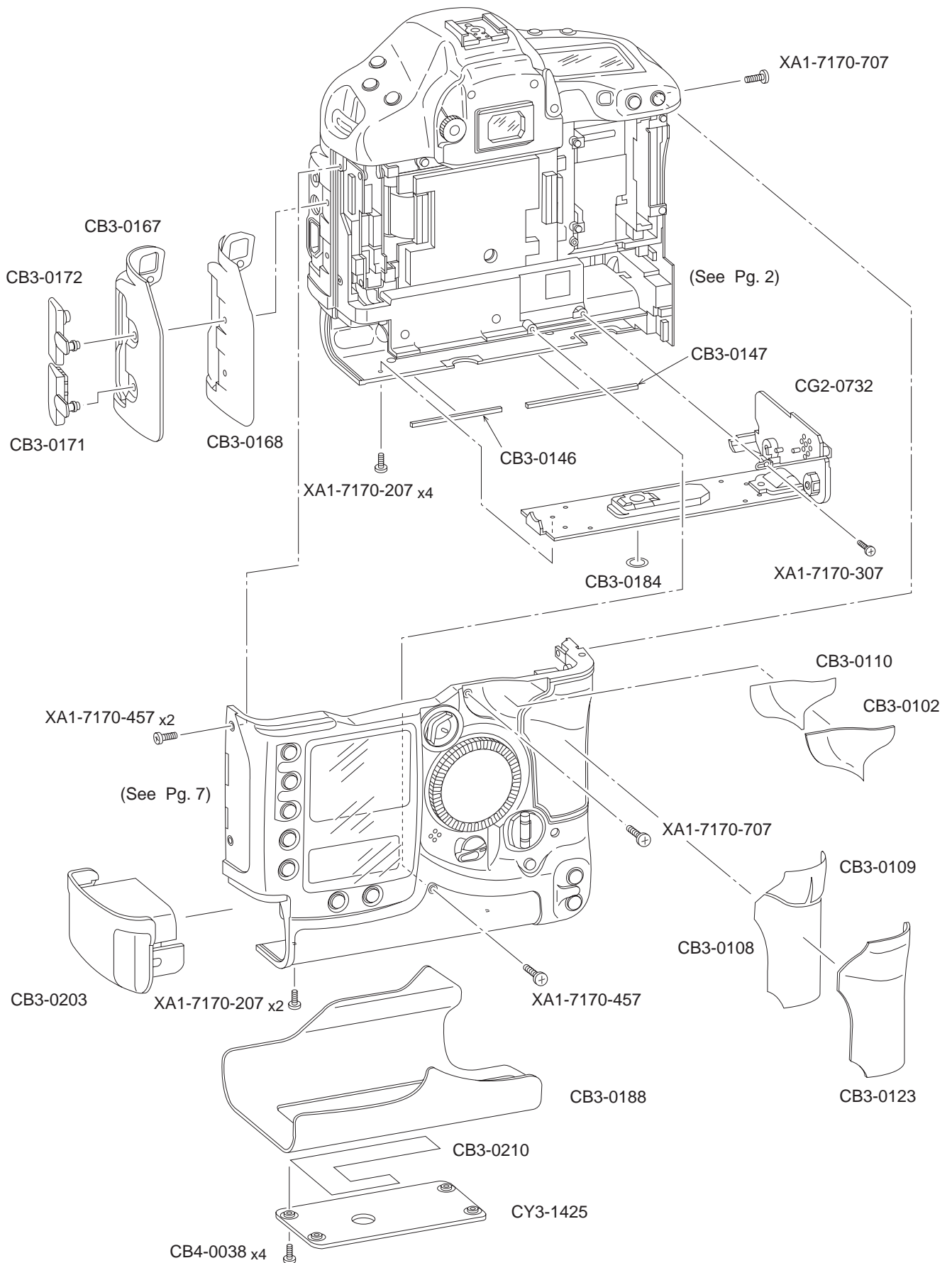

PARTS LIST

REF.NO.C12-6021

PG1

NEW	PARTS No.	CLASS	QTY	DESCRIPTION
	CB3-0102-000	B	1	COVERING, BACK
	CB3-0108-000	B	1	TAPE, DOUBLE SIDED 1 (BACK
	CB3-0109-000	B	1	TAPE, DOUBLE SIDED 2 (BACK
	CB3-0110-000	B	1	TAPE, DOUBLE SIDED 3 (BACK)
	CB3-0123-000	B	1	COVERING, CF
	CB3-0146-000	A	1	SEAL, BACK BOTTOM-TR
	CB3-0147-000	A	1	SEAL, BACK BOTTOM-GR
	CB3-0167-000	B	1	COVERING, FRONT
	CB3-0168-000	B	1	TAPE, DOUBLE SIDED (FRONT
	CB3-0171-000	C	1	CAP, TERMINAL
	CB3-0172-000	C	1	CAP, PC-REMOTE
	CB3-0184-000	A	1	SEAL, O RING TRIPOD
	CB3-0188-000	B	1	COVERING, BOTTOM
	CB3-0203-000	C	1	CAP, BATTERY
	CB3-0210-000	C	2	TAPE, DOUBLE SIDED (TRIPOD)
	CB4-0038-000	C	4	SCREW, CROSS-RECESS, PH
	CG2-0732-000	B	1	B-CONT HOLDER UNIT
*	CY3-1425-000	C	1	NAME, PLATE
	XA1-7170-207	F	6	SCREW, CROSS-RECESS, PH
	XA1-7170-307	F	1	SCREW, CROSS-RECESS, PH
	XA1-7170-457	F	3	SCREW, CROSS-RECESS, PH
	XA1-7170-707	F	2	SCREW, CROSS-RECESS, PH

CANON DIGITAL CAMERA EOS-1Ds

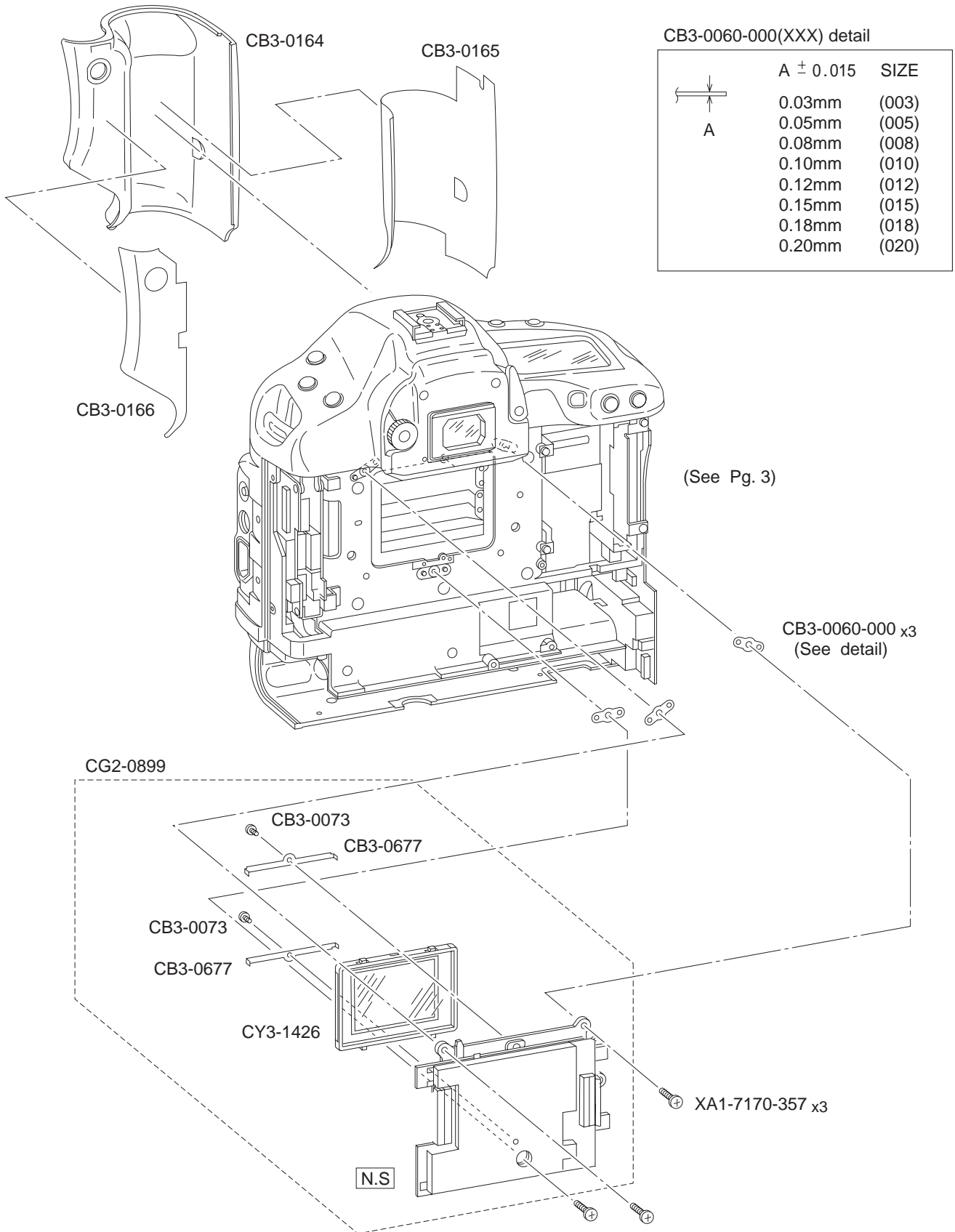

PARTS LIST

REF.NO.C12-6021

PG2

NEW	PARTS No.	CLASS	QTY	DESCRIPTION
	CB3-0060-000 (XXX)	C	3	WASHER, FLANGE BACK
	CB3-0073-000	C	2	SCREW, CROSS-RECESS, PH
	CB3-0164-000	B	1	COVERING, GRIP
	CB3-0165-000	B	1	TAPE, DOUBLE SIDED1 GRIP
	CB3-0166-000	B	1	TAPE, DOUBLE SIDED2 GRIP
*	CB3-0677-000	C	2	SPRING, LOW PASS FILTER
*	CG2-0899-000	B	1	PCB ASS'Y, IMAGE
*	CY3-1426-000	B	1	FILTER ASS'Y, LOW PASS
	XA1-7170-357	F	3	SCREW, CROSS-RECESS, PH

CANON DIGITAL CAMERA EOS-1Ds

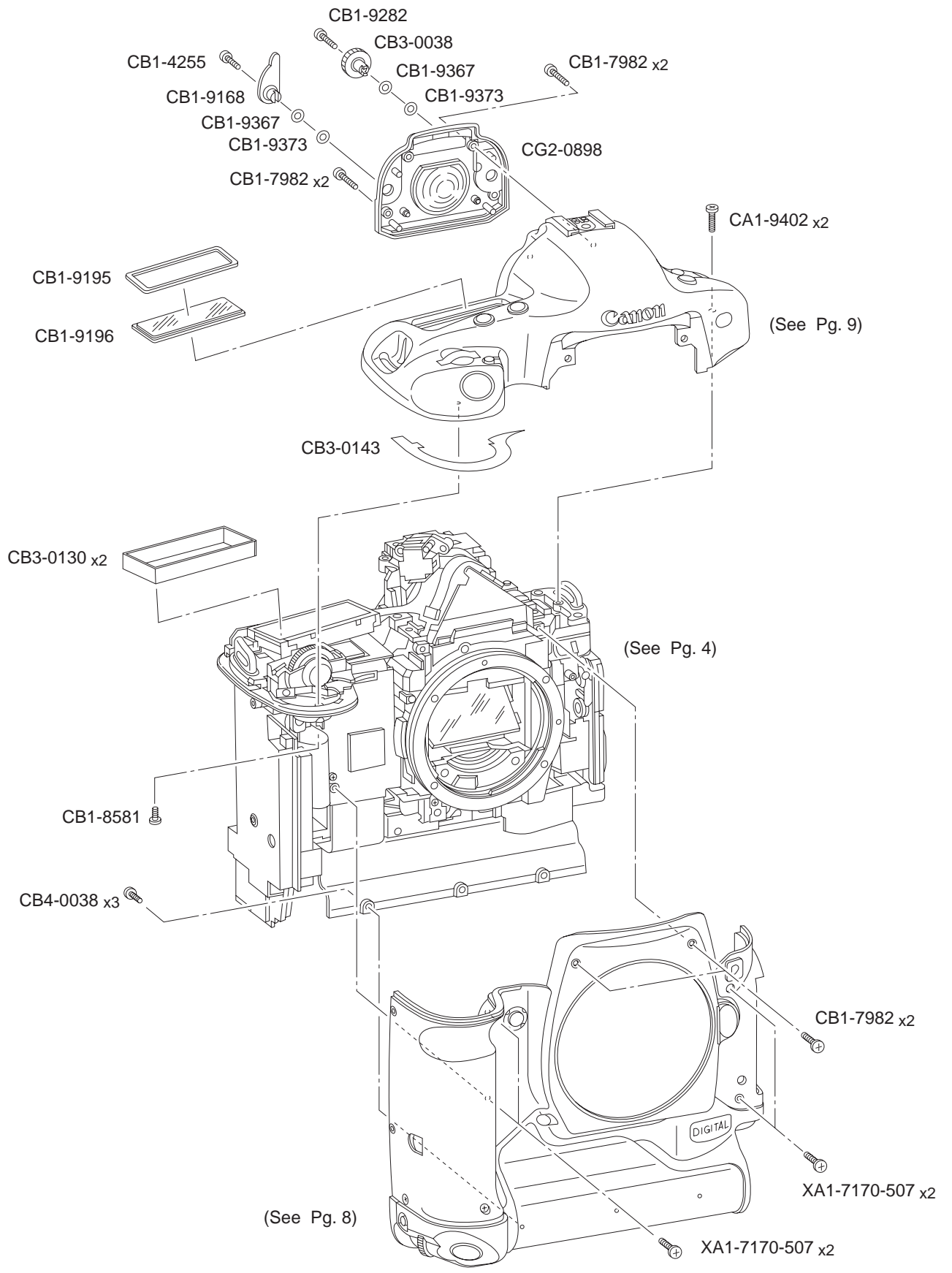

PARTS LIST

REF.NO.C12-6021

PG3

NEW	PARTS No.	CLASS	QTY	DESCRIPTION
	CA1-9402-000	C	2	SCREW, CROSS-RECESS, PH
	CB1-4255-000	C	1	SCREW, CROSS-RECESS, PH
	CB1-7982-000	C	6	SCREW, CROSS-RECESS, PH
	CB1-8581-000	C	1	SCREW, CROSS-RECESS, PH
	CB1-9168-000	C	1	EYEPIECE SH LEVER
	CB1-9195-000	C	1	MASK, OLC
	CB1-9196-000	C	1	WINDOW, OLC
	CB1-9282-000	C	1	SCREW, CROSS-RECESS, PH
	CB1-9367-000	B	2	DIAL O-RING
	CB1-9373-000	C	2	EYEPIECE SLIDER
	CB3-0038-000	C	1	DIAL, EYEPIECE ADJUSTING
	CB3-0130-000	B	2	SHIELD, LIGHT (OLC)
	CB3-0143-000	A	1	SEAL, TOP-CAP
	CB4-0038-000	C	3	SCREW, CROSS-RECESS, PH
*	CG2-0898-000	C	1	EYEPIECE COVER UNIT
	XA1-7170-507	F	4	SCREW, CROSS-RECESS, PH

CANON DIGITAL CAMERA EOS-1Ds

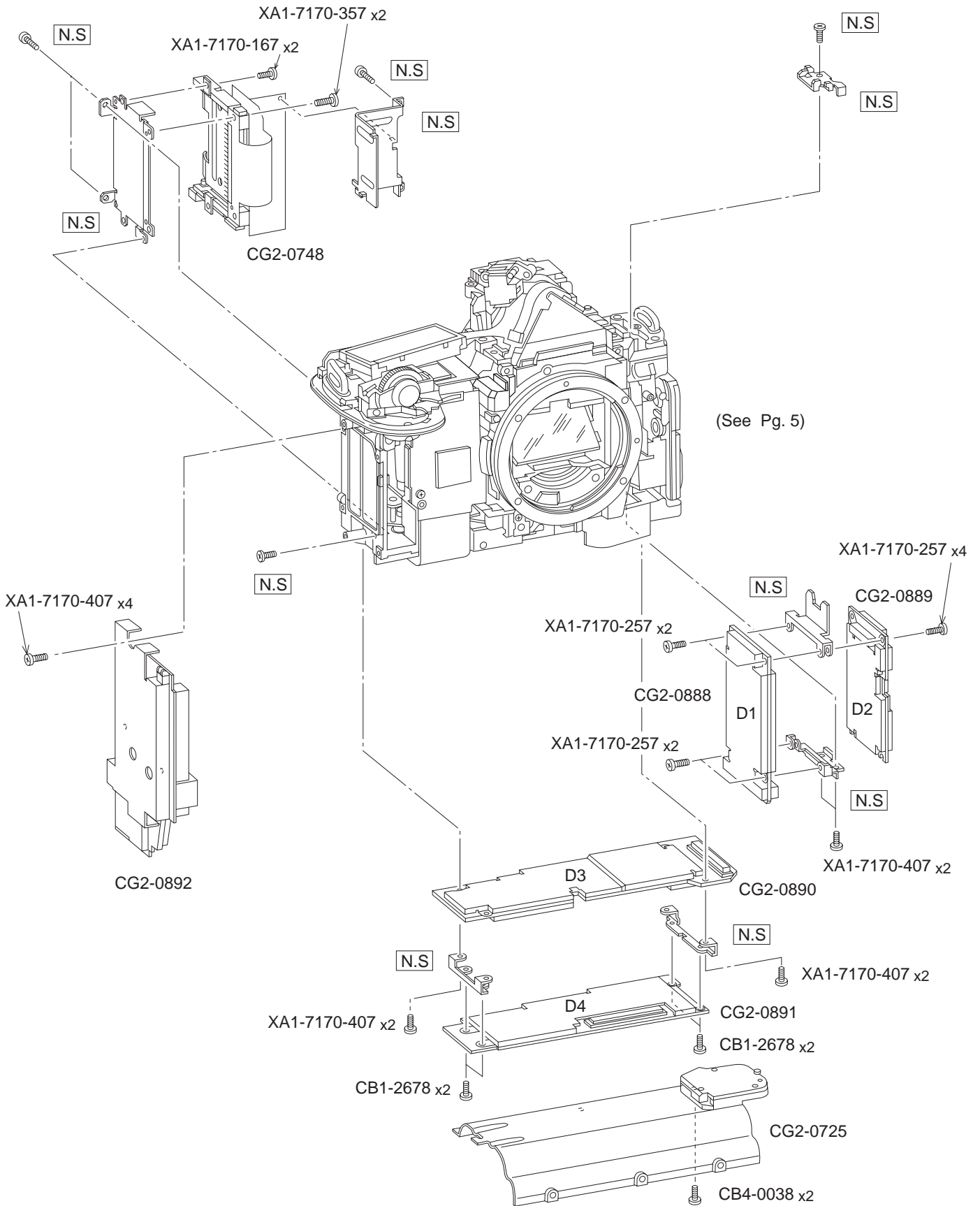

PARTS LIST

REF.NO.C12-6021

PG4

NEW	PARTS No.	CLASS	QTY	DESCRIPTION
	CB1-2678-000	C	4	SCREW, CROSS-RECESS, PH
	CB3-0211-000	C	1	SEAL, INSULATING DC/DC
	CB4-0038-000	C	2	SCREW, CROSS-RECESS, PH
	CB4-0423-000	C	1	COVER, BATTERY
*	CG2-0888-000	B	1	PCB ASS'Y, D1
*	CG2-0889-000	B	1	PCB ASS'Y, D2
*	CG2-0890-000	B	1	PCB ASS'Y, D3
*	CG2-0891-000	B	1	PCB ASS'Y, D4
*	CG2-0892-000	B	1	PCB ASS'Y, DC/DC
	CG2-0725-000	C	1	BATTERY PLATE UNIT
	CG2-0748-000	C	1	PCB ASS'Y, CF
*	CH1-8075-000	C	1	FPC, A-D2
	XA1-7170-167	F	2	SCREW, CROSS-RECESS, PH
	XA1-7170-257	F	8	SCREW, CROSS-RECESS, PH
	XA1-7170-357	F	2	SCREW, CROSS-RECESS, PH
	XA1-7170-407	F	10	SCREW, CROSS-RECESS, PH

CANON DIGITAL CAMERA EOS-1Ds

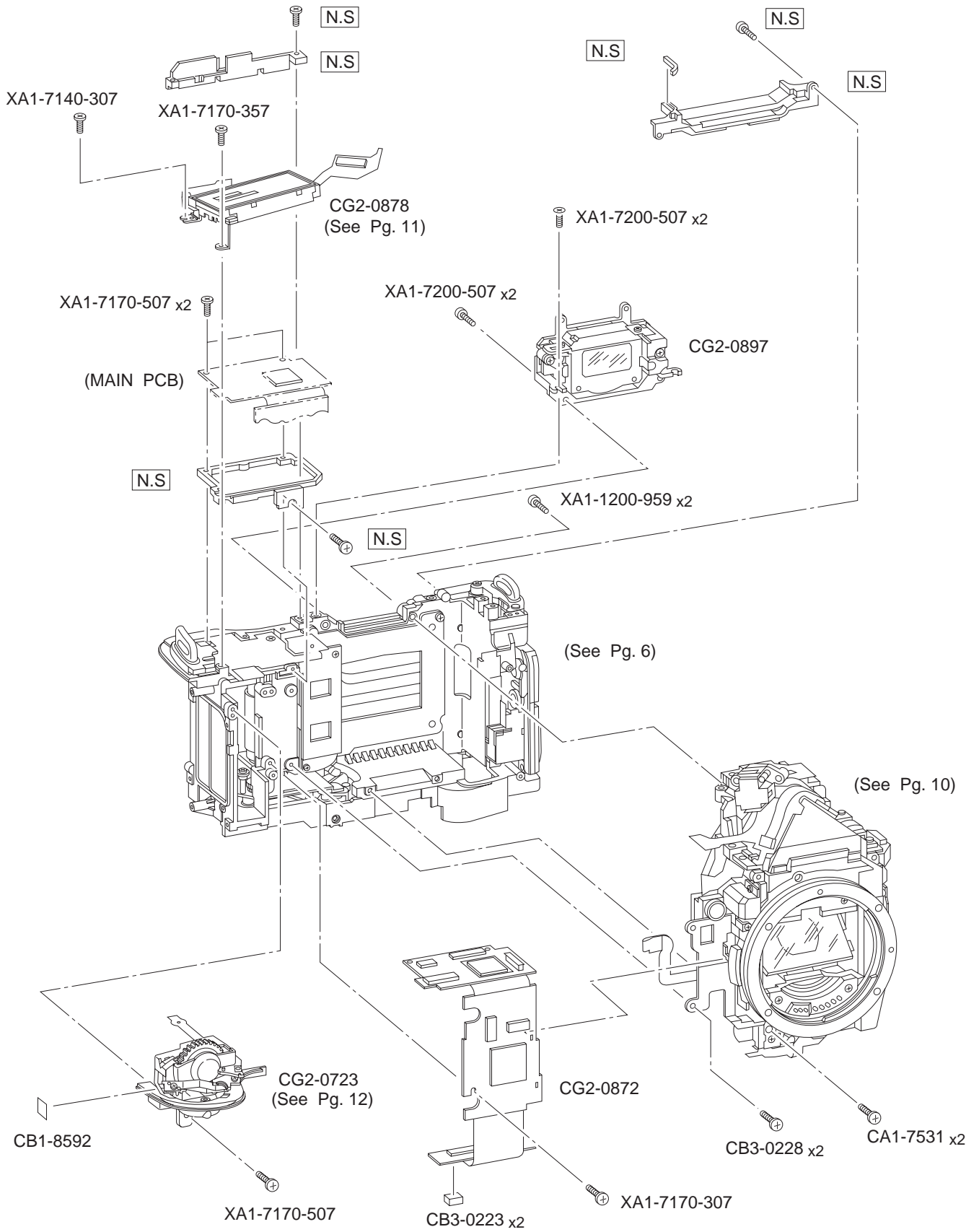

PARTS LIST

REF.NO.C12-6021

PG5

NEW	PARTS No.	CLASS	QTY	DESCRIPTION
	CA1-7531-000	C	2	SCREW, CROSS-RECESS, PH
	CB3-0223-000	C	2	CUSHION, MAIN PCB
	CB3-0228-000	C	2	SCREW, CROSS-RECESS, PH
	CG2-0723-000	B	1	DIAL UNIT
*	CG2-0872-000	B	1	PCB ASS'Y, MAIN
*	CG2-0878-000	B	1	LCD, EXTERNAL
*	CG2-0897-000	B	1	EYEPIECE UNIT
	XA1-1200-959	F	2	SCREW, CROSS-RECESS, PH
	XA1-7140-307	F	1	SCREW, CROSS-RECESS, PH
	XA1-7170-307	F	1	SCREW, CROSS-RECESS, PH
	XA1-7170-357	F	1	SCREW, CROSS-RECESS, PH
	XA1-7170-507	F	3	SCREW, CROSS-RECESS, PH
	XA1-7200-507	F	4	SCREW, CROSS-RECESS, PH

CANON DIGITAL CAMERA EOS-1Ds

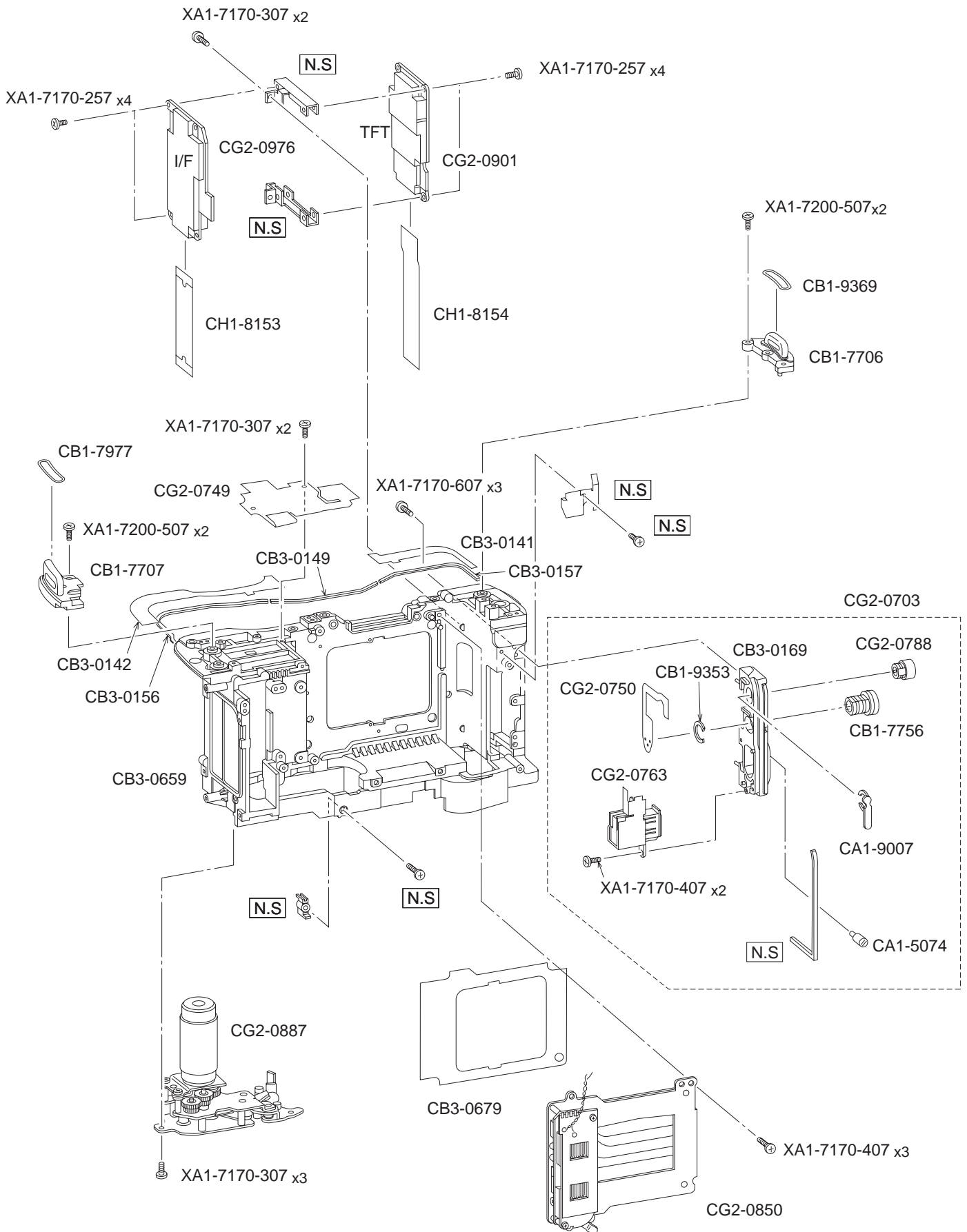

PARTS LIST

REF.NO.C12-6021

PG6

NEW	PARTS No.	CLASS	QTY	DESCRIPTION
	CA1-5074-000	E	1	SCREW, STOPPER
	CA1-9007-000	B	1	RING, PC RETAINER
	CB1-7706-000	C	1	STRAP RING L
	CB1-7707-000	C	1	RING, STRAP (R)
	CB1-7756-000	B	1	3P-RECEPTACLE
	CB1-7977-000	C	1	SEAL, STRAP R
	CB1-9353-000	C	1	STOPPER, RT SOCKET
	CB1-9369-000	C	1	SEAL, STRAP L
	CB3-0141-000	A	1	SEAL, TOP-TR
	CB3-0142-000	A	1	SEAL, TOP-BACK
	CB3-0149-000	A	1	SEAL, BACK BODY
	CB3-0156-000	A	1	SEAL, BACK BODY-GR
	CB3-0157-000	A	1	SEAL, BACK BODY-TR
	CB3-0169-000	B	1	HOLDER, TERMINAL
*	CB3-0659-000	A	1	BODY
*	CB3-0679-000	C	1	TAPE, DUST
	CG2-0703-000	B	1	TERMINAL ASS'Y, INTERFACE
	CG2-0749-000	B	1	PCB ASS'Y, MOTOR DRIVE
	CG2-0750-000	C	1	PCB ASS'Y, REMOTE
	CG2-0763-000	B	1	CONNECTOR ASS'Y, 1394
	CG2-0788-000	B	1	PC TERMINAL UNIT
*	CG2-0850-000	B	1	SHUTTER UNIT
*	CG2-0887-000	B	1	CHARGE UNIT
*	CG2-0901-000	B	1	PCB ASS'Y, TFT
*	CG2-0976-000	B	1	PCB ASS'Y, INTERFACE
*	CH1-8153-000	B	1	FPC, RELAY IF TO D4
*	CH1-8154-000	B	1	FPC, RELAY TFT TO D4
	XA1-7170-257	F	8	SCREW, CROSS-RECESS, PH
	XA1-7170-307	F	7	SCREW, CROSS-RECESS, PH
	XA1-7170-407	F	5	SCREW, CROSS-RECESS, PH
	XA1-7170-607	F	3	SCREW, CROSS-RECESS, PH
	XA1-7200-507	F	4	SCREW, CROSS-RECESS, PH

CANON DIGITAL CAMERA EOS-1Ds

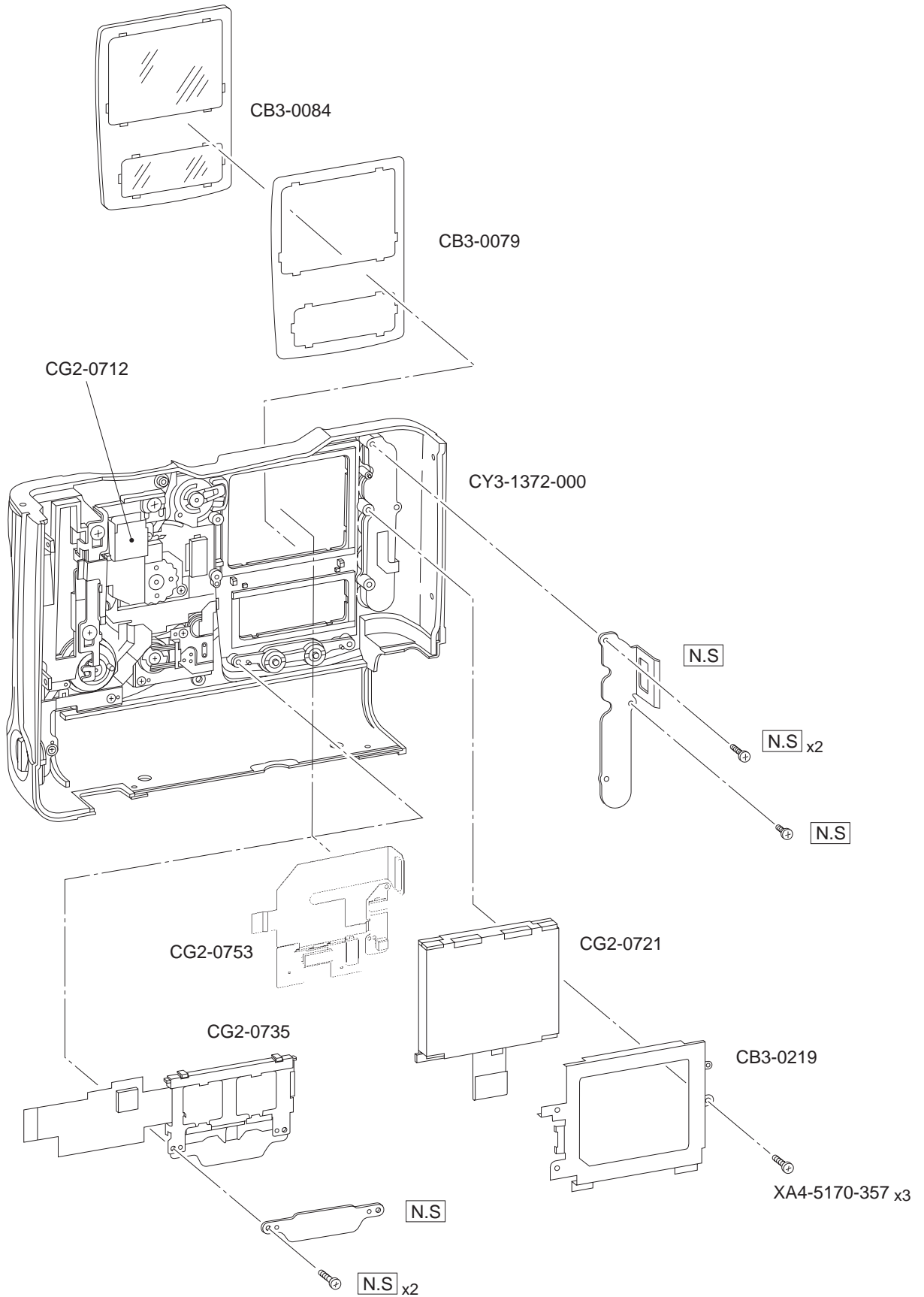

PARTS LIST

REF.NO.C12-6021

PG7

NEW	PARTS No.	CLASS	QTY	DESCRIPTION
	CB3-0079-000	C	1	TAPE, TFT DOUBLE SIDED
	CB3-0084-000	B	1	WINDOW, TFT
	CB3-0219-000	C	1	TFT HOLDER
	CG2-0712-000	C	1	INVERTER ASS'Y
	CG2-0721-000	B	1	TFT LCD UNIT
	CG2-0735-000	C	1	LCD ASS'Y, BACK COVER
	CG2-0753-000	C	1	FPC, BACK MODULE
	CY3-1372-000	C	1	COVER ASS'Y, BACK
	XA4-5170-357	F	3	SCREW, CROSS-RECESS, PH

CANON DIGITAL CAMERA EOS-1Ds

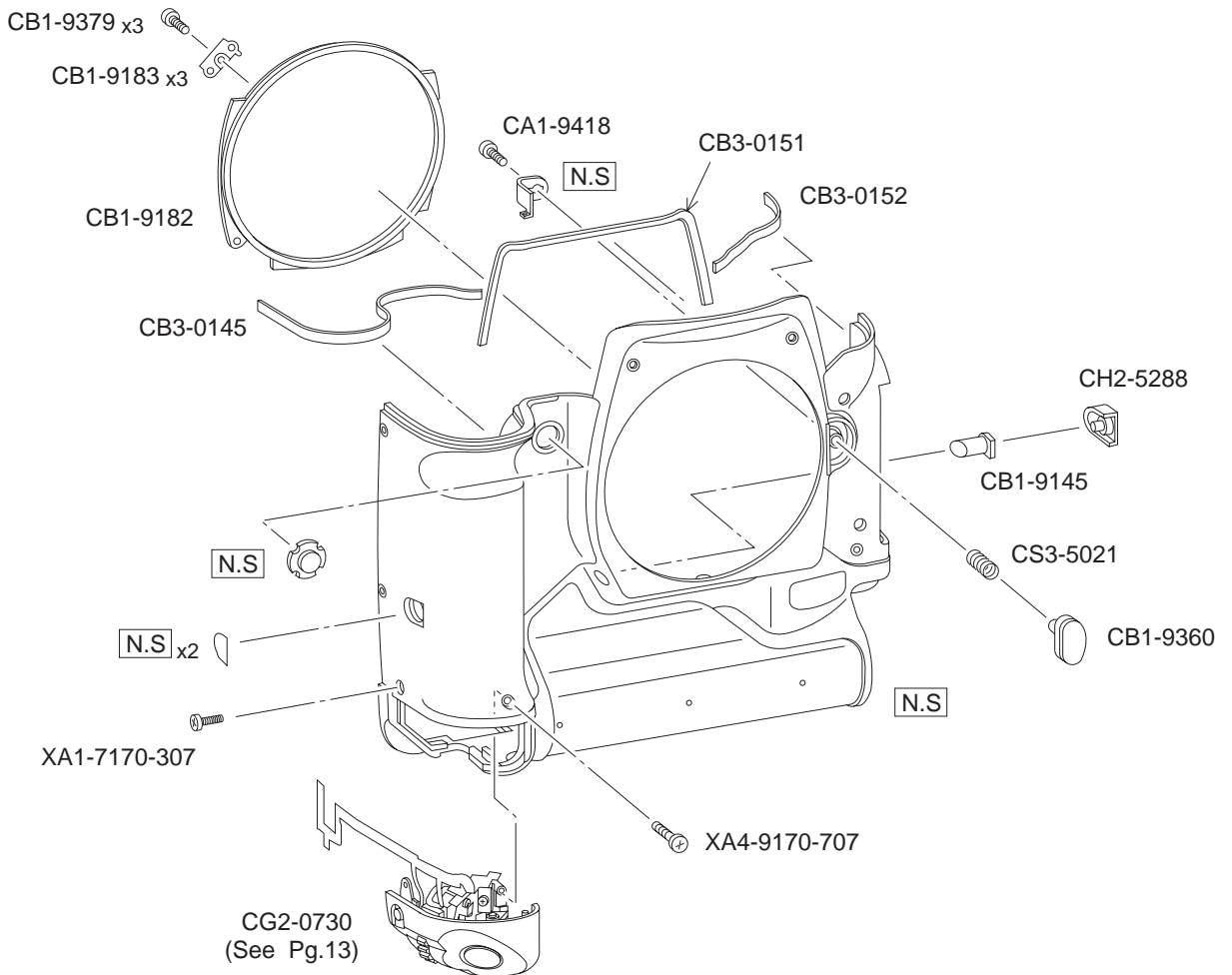
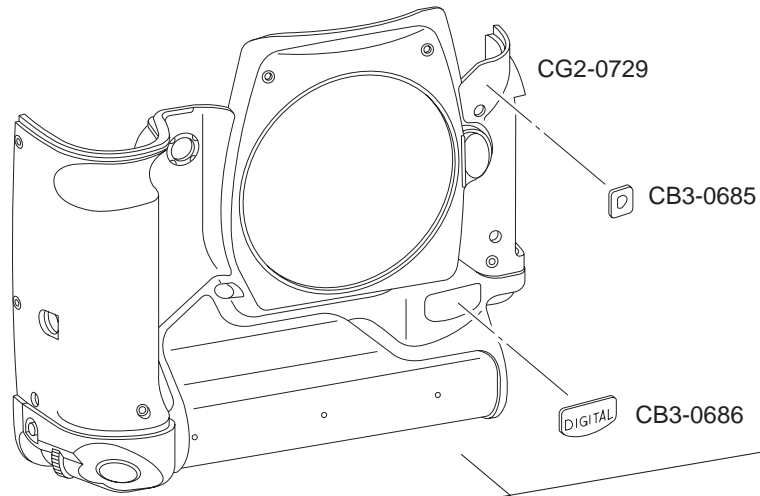

PARTS LIST

REF.NO.C12-6021

PG8

NEW	PARTS No.	CLASS	QTY	DESCRIPTION
	CA1-9418-000	B	1	SCREW, CROSS-RECESS, PH
	CB1-9145-000	C	1	BUTTON, PV
	CB1-9182-000	C	1	RING, MOUNT
	CB1-9183-000	C	3	PLATE, MOUNT RING
	CB1-9360-000	C	1	BUTTON, UNLOCK
	CB1-9379-000	F	3	SCREW, CROSS-RECESS, PH
	CB3-0145-000	A	1	SEAL, FRONT-GR
	CB3-0151-000	A	1	SEAL, FRONT-MID
	CB3-0152-000	A	1	SEAL, FRONT-TR
*	CB3-0685-000	B	1	PLATE, NAME 1Ds
*	CB3-0686-000	B	1	PLATE, NAME DIGITAL
	CG2-0729-000	B	1	FRONT COVER UNIT
	CG2-0730-000	C	1	DIAL ASS'Y, VERTICAL
	CH2-5288-000	C	1	SWITCH, PV
	CS3-5021-000	C	1	SPRING, UNLOCK BUTTON
	XA1-7170-307	F	1	SCREW, CROSS-RECESS, PH
	XA4-9170-707	F	1	SCREW, CROSS-RECESS, PH

CANON DIGITAL CAMERA EOS-1Ds

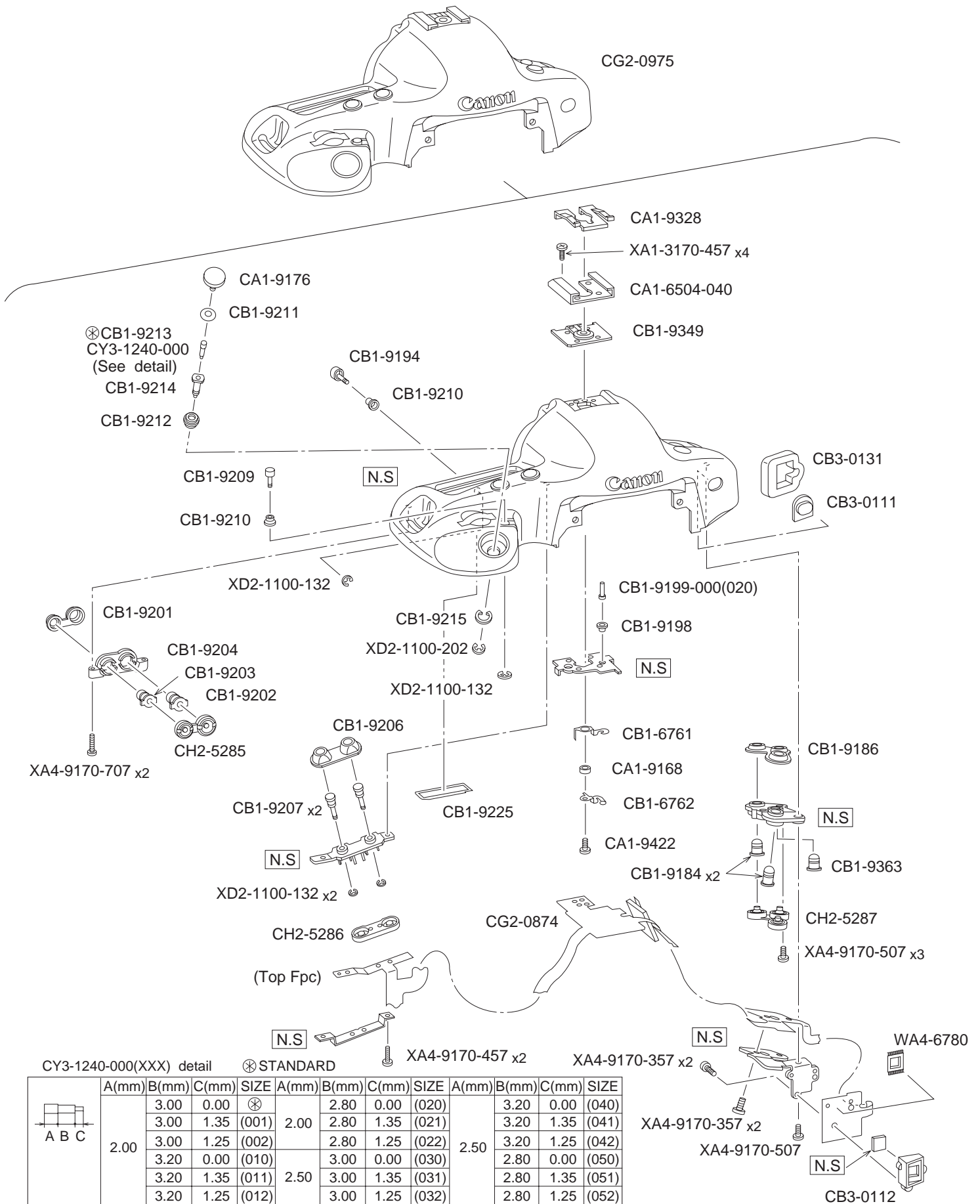

PARTS LIST

REF.NO.C12-6021

PG9

NEW	PARTS No.	CLASS	QTY	DESCRIPTION
	CA1-6504-040	C	1	SHOE, ACCESSORY
	CA1-9168-000	C	1	SPACER, INSULATING
	CA1-9176-000	C	1	BUTTON, RELEASE
	CA1-9328-000	C	1	SPRING, PLATE
	CA1-9422-000	C	1	SCREW, CROSS-RECESS, PH
	CB1-6761-000	C	1	CONTACT, ACCESSORY
	CB1-6762-000	C	1	CONTACT, ACCESSORY X
	CB1-9184-000	C	2	BUTTON, MODE
	CB1-9186-000	C	1	COVER, MODE SWITCH
	CB1-9194-000	C	1	BUTTON, ADD
	CB1-9198-000	C	1	COVER, ACCESSORY SHOE PIN
	CB1-9199-000 (020)	C	1	PIN, ACCESSORY SHOE
	CB1-9201-000	C	1	COVER, BACK SWITCH
	CB1-9202-000	C	1	BUTTON, AEL
	CB1-9203-000	C	1	BUTTON, FPSEL
	CB1-9204-000	C	1	BASE, BACK SWITCH
	CB1-9206-000	C	1	COVER, EL-C SWITCH
	CB1-9207-000	C	2	BUTTON, EL-C
	CB1-9209-000	C	1	BUTTON, FEL
	CB1-9210-000	C	2	COVER, FEL SWITCH
	CB1-9211-000	C	1	COVER, RELEASE
	CB1-9212-000	C	1	GUIDE, RELEASE SHAFT
	CB1-9213-000	C	1	PIN, RELEASE
	CB1-9214-000	C	1	SHAFT, RELEASE
	CB1-9215-000	C	1	RING, RETAINING
	CB1-9225-000	C	1	SEAL, DIAL
	CB1-9349-000	C	1	BASE, ACCESSORY SHOE
	CB1-9363-000	C	1	BUTTON, AF MODE
	CB3-0111-000	B	1	WINDOW, WHITE BALANCE
	CB3-0112-000	B	1	HOLDER, WB IR
	CB3-0131-000	B	1	CUSHION, WB
*	CG2-0874-000	B	1	PCB ASS'Y, TOP
*	CG2-0975-000	B	1	COVER ASS'Y, TOP
	CH2-5285-000	C	1	SWITCH, BACK
	CH2-5286-000	C	1	SWITCH, EL-C
	CH2-5287-000	C	1	SWITCH, MODE
	CY3-1240-000 (XXX)	C	1	SHAFT, ADJUSTING
	WA4-6780-000	B	1	SENSOR, WHITE BALANCE
	XA1-3170-457	F	4	SCREW, CROSS-RECESS, PH
	XA4-9170-357	F	4	SCREW, CROSS-RECESS, PH
	XA4-9170-457	F	2	SCREW, CROSS-RECESS, PH
	XA4-9170-507	F	4	SCREW, CROSS-RECESS, PH
	XA4-9170-707	F	2	SCREW, CROSS-RECESS, PH
	XD2-1100-132	F	4	WASHER, RETAINING 1.3MM
	XD2-1100-202	F	1	WASHER, RETAINING

CANON DIGITAL CAMERA EOS-1Ds

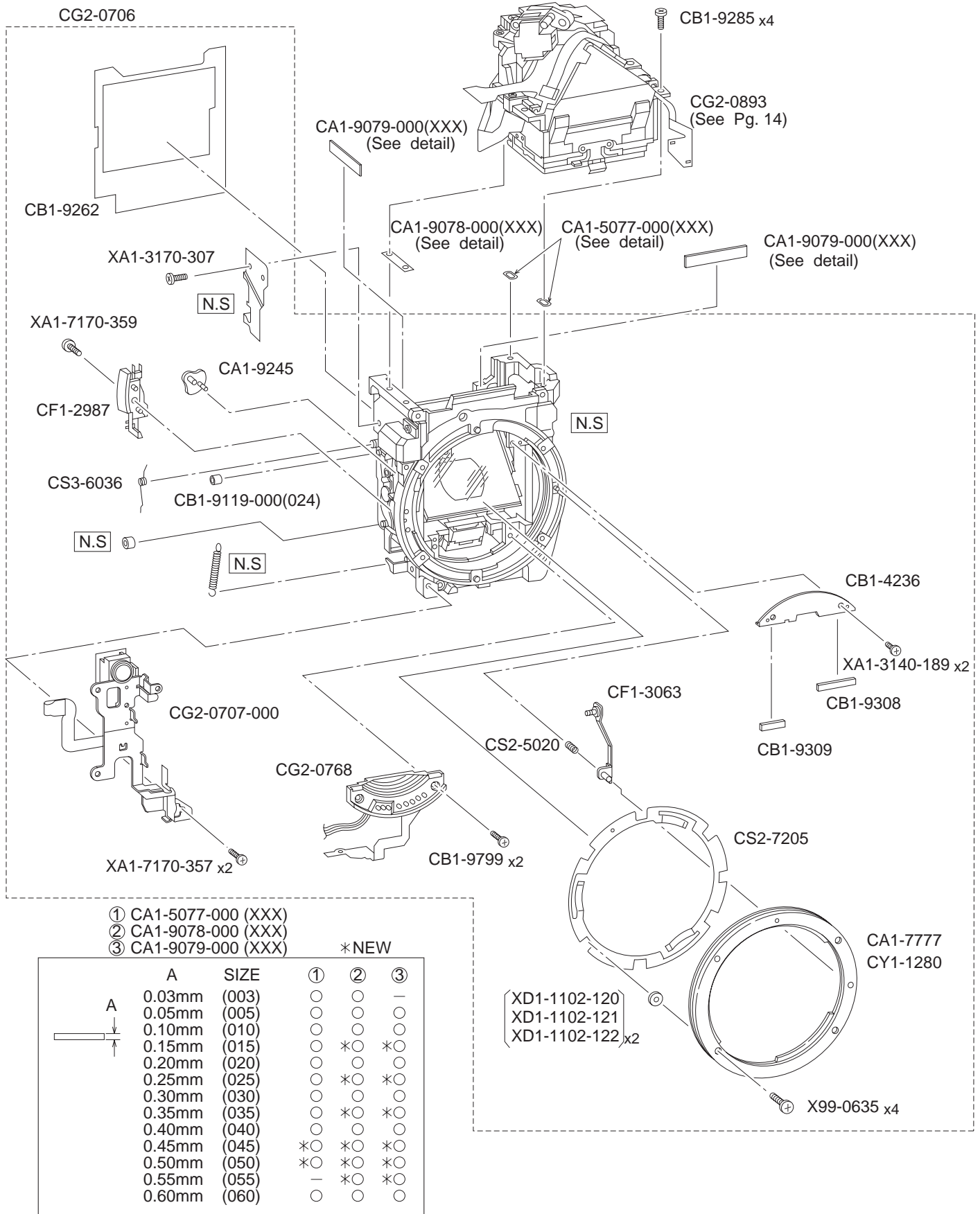

- ① CA1-5077-000 (XXX)
- ② CA1-9078-000 (XXX)
- ③ CA1-9079-000 (XXX)

*NEW

A	SIZE	①	②	③
0.03mm (003)		○	○	—
0.05mm (005)		○	○	—
0.10mm (010)		○	○	○
0.15mm (015)		○	*○	*○
0.20mm (020)		○	○	○
0.25mm (025)		○	*○	*○
0.30mm (030)		○	○	○
0.35mm (035)		○	*○	*○
0.40mm (040)		○	○	○
0.45mm (045)		*○	*○	*○
0.50mm (050)		*○	*○	*○
0.55mm (055)		—	*○	*○
0.60mm (060)		○	○	○

PARTS LIST

REF.NO.C12-6021

PG10

NEW	PARTS No.	CLASS	QTY	DESCRIPTION
	CA1-5077-000 (XXX)	C	2	WASHER, FINDER FOCUSING
	CA1-7777-000	C	1	MOUNT, BODY
	CA1-9078-000 (XXX)	C	1	SHIM, FINDER FOCUSING
	CA1-9079-000 (XXX)	C	2	PLATE, PARALLAX ADJUSTING
	CA1-9245-000	E	1	LEVER, SENSOR
	CB1-4236-000	C	1	PLATE, LIGHT SHIELD
	CB1-9119-000 (024)	C	1	COLLAR
	CB1-9262-000	C	1	SHIELD, LIGHT
	CB1-9285-000	C	4	SCREW, CROSS-RECESS, PH
	CB1-9308-000	C	1	CUSHION, MIRROR 1
	CB1-9309-000	C	1	CUSHION, MIRROR 2
	CB1-9799-000	C	2	SCREW, CROSS-RECESS, PH
	CF1-2987-000	C	1	SWITCH, LENS
	CF1-3063-000	C	1	LOCK PIN UNIT
	CG2-0706-000	B	1	FRONT PANEL UNIT
	CG2-0707-000	B	1	WING PLATE UNIT
	CG2-0768-000	B	1	CONTACT ASS'Y, MOUNT
*	CG2-0893-000	B	1	PENTAPRISM UNIT
	CS2-5020-000	C	1	SPRING, COIL
	CS2-7205-000	C	1	SPRING, MOUNT
	CS3-6036-000	C	1	SPRING, MIRROR
	CY1-1280-000	C	1	MOUNT, BODY (0.1mm under)
	X99-0635-000	F	4	SCREW, CROSS-RECESS, PH
	XA1-3140-189	F	2	SCREW, CROSS-RECESS, FCH
	XA1-3170-307	F	1	SCREW, CROSS-RECESS, PH
	XA1-7170-357	F	2	SCREW, CROSS-RECESS, PH
	XA1-7170-359	F	1	SCREW, CROSS-RECESS, PH
	XD1-1102-120	F	2	WASHER (0.05mm)
	XD1-1102-121	F	2	WASHER (0.1mm)
	XD1-1102-122	F	2	WASHER (0.2mm)

CANON DIGITAL CAMERA EOS-1Ds

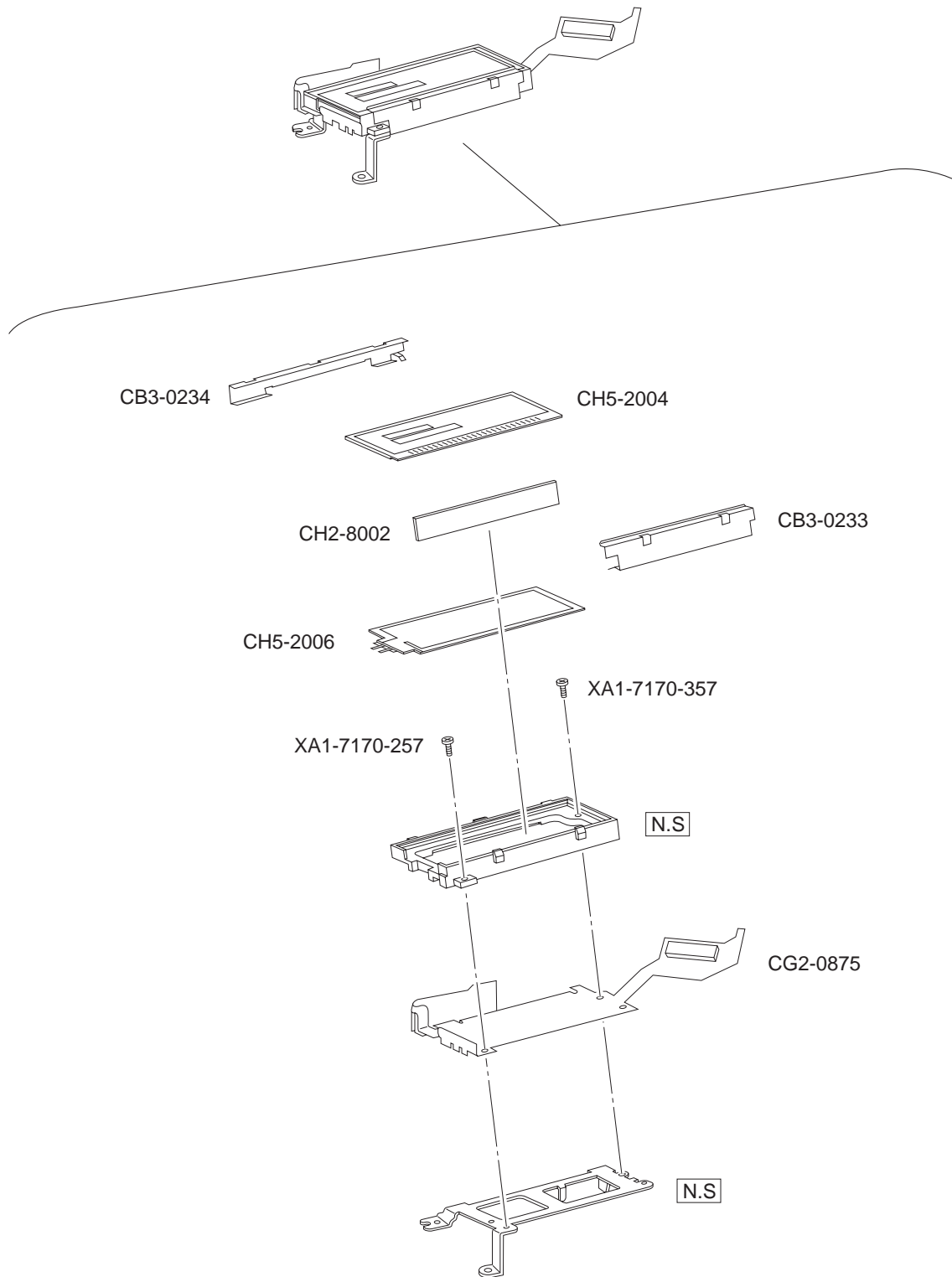

PARTS LIST

REF.NO.C12-6021

PG11

NEW	PARTS No.	CLASS	QTY	DESCRIPTION
	CB3-0233-000	C	1	HOLDER, OLC 1
	CB3-0234-000	C	1	HOLDER, OLC 2
*	CG2-0875-000	B	1	PCB ASS'Y, DISPLAY
	CH2-8002-000	C	1	CONNECTOR, OLC
	CH5-2004-000	B	1	LCD, EXTERNAL
	CH5-2006-000	B	1	ELECTRO LUMINESCENCE
	XA1-7170-257	F	1	SCREW, CROSS-RECESS, PH
	XA1-7170-357	F	1	SCREW, CROSS-RECESS, PH

CANON DIGITAL CAMERA EOS-1Ds

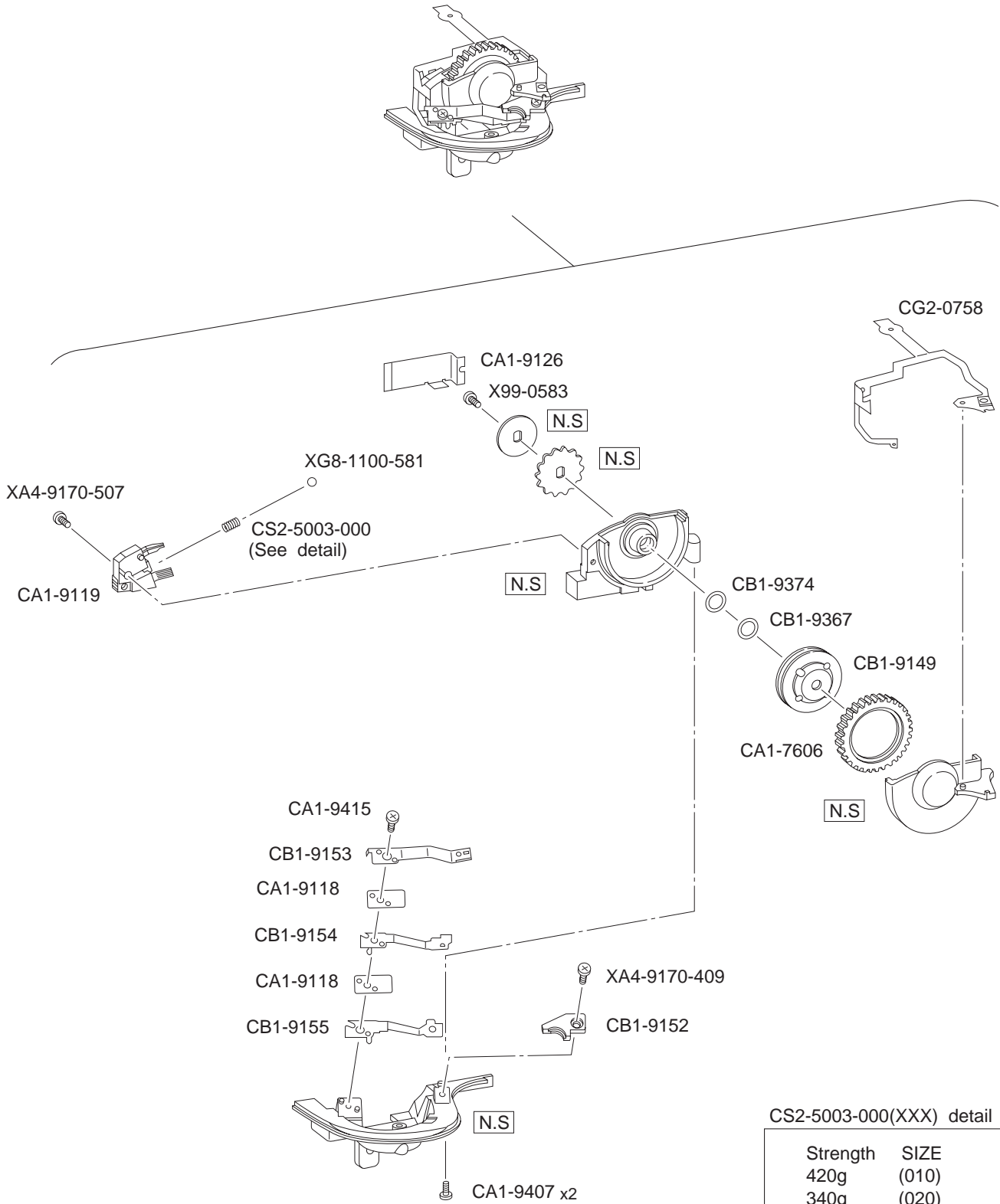

CS2-5003-000(XXX) detail

Strength	SIZE
420g	(010)
340g	(020)
* 300g	(030)
* STANDARD	

PARTS LIST

REF.NO.C12-6021

PG12

NEW	PARTS No.	CLASS	QTY	DESCRIPTION
	CA1-7606-000	C	1	RING, DIAL
	CA1-9118-000	C	2	SPACER, CONTACT
	CA1-9119-000	C	1	CONTACT, DIAL
	CA1-9126-000	C	1	COVER, DIAL CONTACT
	CA1-9407-000	C	2	SCREW, CROSS-RECESS, PH
	CA1-9415-000	C	1	SCREW, CROSS-RECESS, PH
	CB1-9149-000	C	1	DIAL, MODE CHANGE
	CB1-9152-000	C	1	PLATE, RELEASE STOPPER
	CB1-9153-000	C	1	CONTACT, RELEASE GROUND
	CB1-9154-000	C	1	CONTACT, RELEASE SWITCH 1
	CB1-9155-000	C	1	CONTACT, RELEASE SWITCH 2
	CB1-9367-000	C	1	O RING
	CB1-9374-000	C	1	SPACER, DIAL
	CG2-0758-000	C	1	PCB ASS'Y, AD SWITCH
	CS2-5003-000 (XXX)	C	1	SPRING, COIL
	X99-0583-000	F	1	SCREW, CROSS-RECESS, PH
	XA4-9170-409	F	1	SCREW, CROSS-RECESS, PH
	XA4-9170-507	F	1	SCREW, CROSS-RECESS, PH
	XG8-1100-581	F	1	BALL, STEEL

CANON DIGITAL CAMERA EOS-1Ds

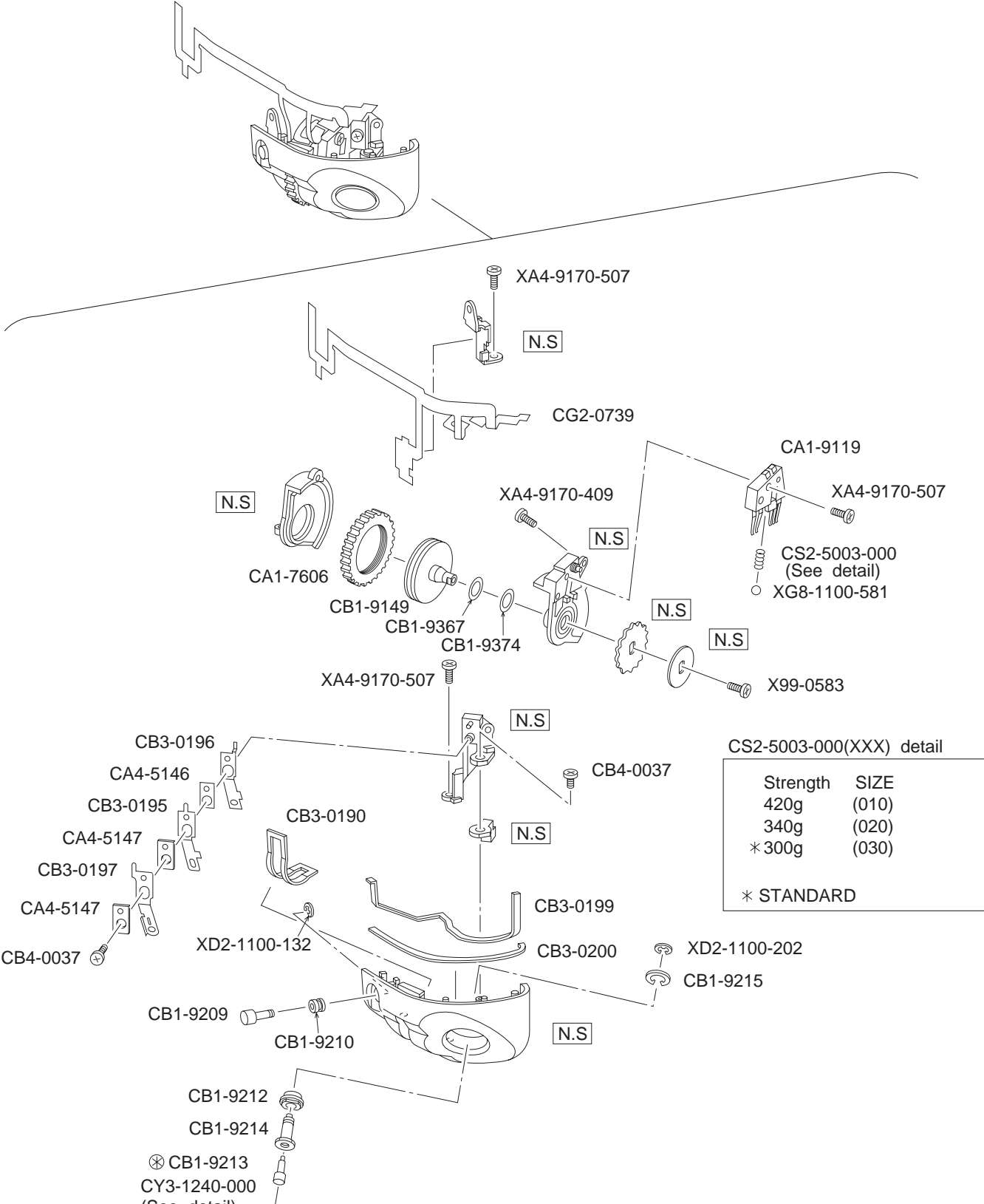

CS2-5003-000(XXX) detail

Strength	SIZE
420g	(010)
340g	(020)
* 300g	(030)

* STANDARD

CY3-1240-000(XXX) detail ⊗ STANDARD

A B C	2.00				2.50				2.50			
	A(mm)	B(mm)	C(mm)	SIZE	A(mm)	B(mm)	C(mm)	SIZE	A(mm)	B(mm)	C(mm)	SIZE
A B C		3.00	0.00	⊗	2.00	2.80	0.00	(020)	2.50	3.20	0.00	(040)
		3.00	1.35	(001)		2.80	1.35	(021)		3.20	1.35	(041)
		3.00	1.25	(002)		2.80	1.25	(022)		3.20	1.25	(042)
		3.20	0.00	(010)	2.50	3.00	0.00	(030)		2.80	0.00	(050)
		3.20	1.35	(011)		3.00	1.35	(031)		2.80	1.35	(051)
		3.20	1.25	(012)		3.00	1.25	(032)		2.80	1.25	(052)

PARTS LIST

REF.NO.C12-6021

PG13

NEW	PARTS No.	CLASS	QTY	DESCRIPTION
	CA1-7606-000	C	1	RING, DIAL
	CA1-9119-000	C	1	CONTACT, DIAL
	CA1-9176-000	C	1	BUTTON, RELEASE
	CA4-5146-000	D	1	SPACER, RELEASE 1
	CA4-5147-000	D	2	SPACER, RELEASE 2
	CB1-9149-000	C	1	DIAL, MODE CHANGE
	CB1-9209-000	C	1	BUTTON, FEL
	CB1-9210-000	C	1	COVER, FEL SWITCH
	CB1-9211-000	C	1	COVER, RELEASE
	CB1-9212-000	C	1	GUIDE, RELEASE SHAFT
	CB1-9213-000	C	1	PIN, RELEASE
	CB1-9214-000	C	1	SHAFT, RELEASE
	CB1-9215-000	C	1	RING, RETAINING
	CB1-9367-000	C	1	O RING
	CB1-9374-000	C	1	SPACER, DIAL
	CB3-0190-000	B	1	SEAL, V DIAL
	CB3-0195-000	B	1	CONTACT, RELEASE SW1
	CB3-0196-000	B	1	CONTACT, RELEASE SW2
	CB3-0197-000	B	1	CONTACT, RELEASE GND
	CB3-0199-000	B	1	SEAL, V CAP 1
	CB3-0200-000	B	1	SEAL, V CAP 2
	CB4-0037-000	F	2	SCREW, CROSS-RECESS, PH
*	CG2-0739-000	B	1	PCB ASS'Y, VERTICAL DIAL
	CS2-5003-000 (XXX)	C	1	SPRING, COIL
	CY3-1240-000	C	1	PIN, RELEASE
	X99-0583-000	F	1	SCREW, CROSS-RECESS, PH
	XA4-9170-409	F	1	SCREW, CROSS-RECESS, PH
	XA4-9170-507	F	3	SCREW, CROSS-RECESS, PH
	XD2-1100-132	F	1	WASHER, RETAINING 1.3MM
	XD2-1100-202	F	1	WASHER, RETAINING
	XG8-1100-581	F	1	BALL, STEEL

CANON DIGITAL CAMERA EOS-1Ds

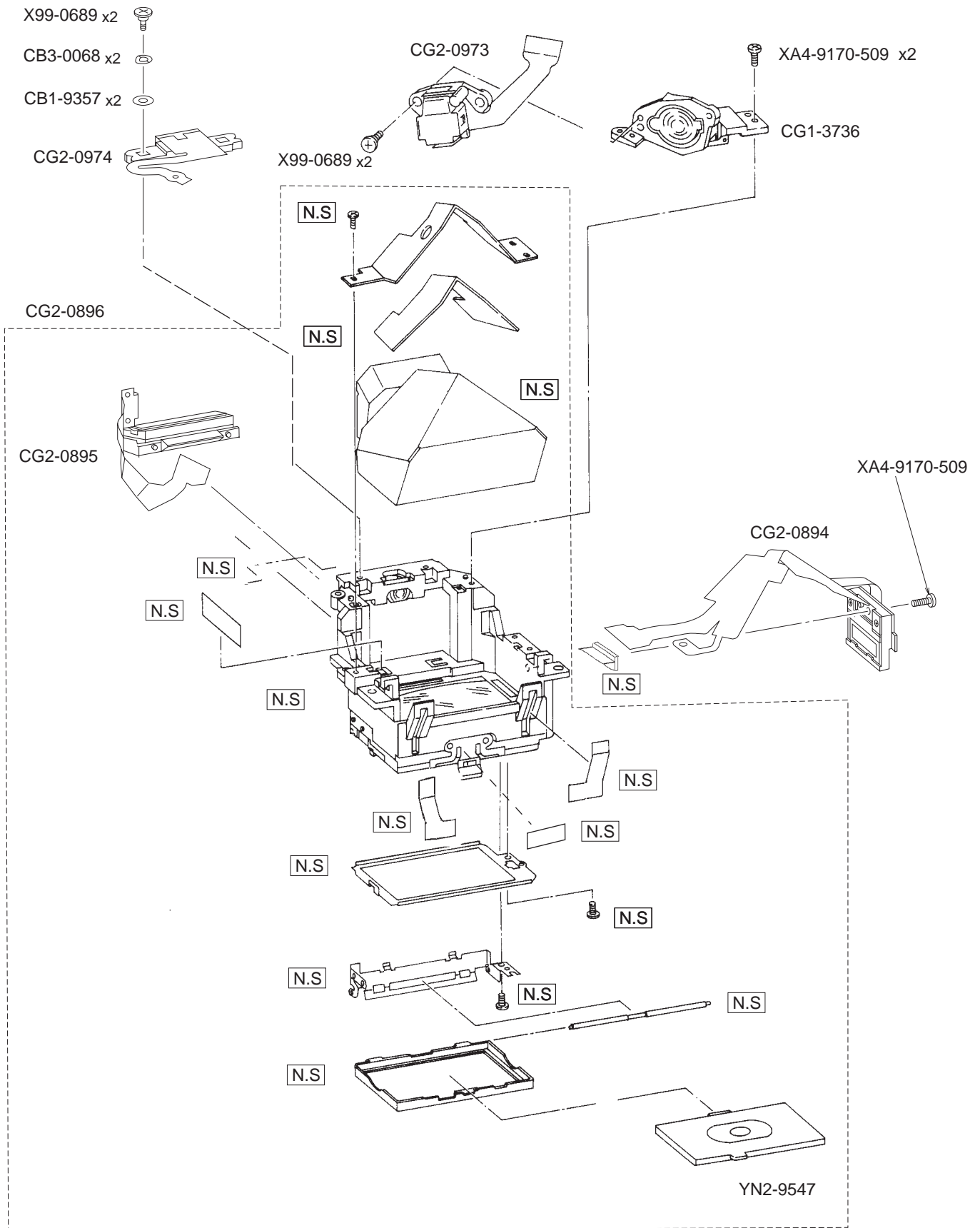

PARTS LIST

REF.NO.C12-6021

PG14

NEW	PARTS No.	CLASS	QTY	DESCRIPTION
	CB1-9357-000	C	2	WASHER, SPC
	CB3-0068-000	C	2	WASHER 2, SPC
	CG1-3736-000	C	1	SI SUPPORT UNIT
*	CG2-0894-000	B	1	VERTICAL LCD UNIT
*	CG2-0895-000	B	1	HORIZONTAL LCD UNIT
*	CG2-0896-000	B	1	PENTAPRISM HOLDER UNIT
*	CG2-0973-000	B	1	SLC UNIT
*	CG2-0974-000	B	1	SPC UNIT
	X99-0689-000	F	4	SCREW, CROSS-RECESS, PH
	XA4-8170-409	F	2	SCREW, CROSS-RECESS, PH
	XA4-9140-307	F	2	SCREW, CROSS-RECESS, PH
	XA4-9170-409	F	2	SCREW, CROSS-RECESS, PH
	XA4-9170-509	F	3	SCREW, CROSS-RECESS, PH
	YN2-9547-000	B	1	SCREEN, FOCUSING

CANON Ni-MH PACK NP-E3

REF.NO.C50-8041
C50-8042

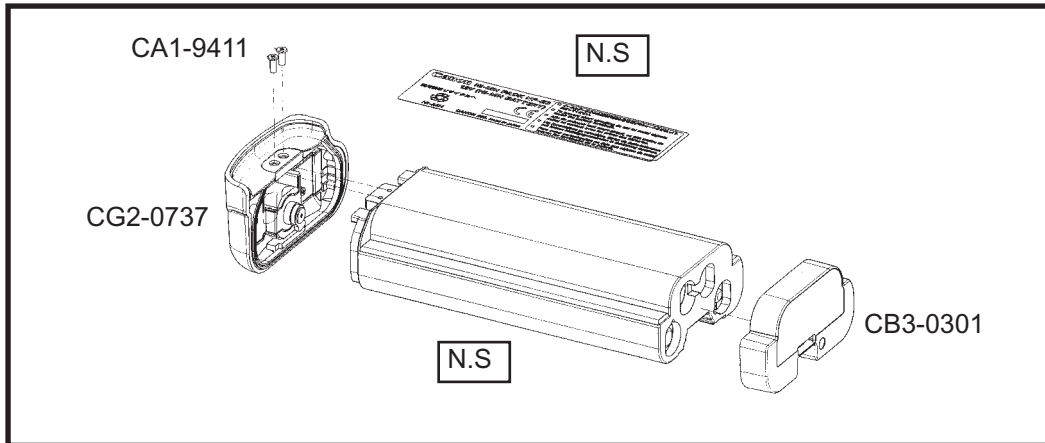

CANON NECK STRAP L4

REF.NO.C56-1731

NECK STRAP L4 (without eyepiece cover)

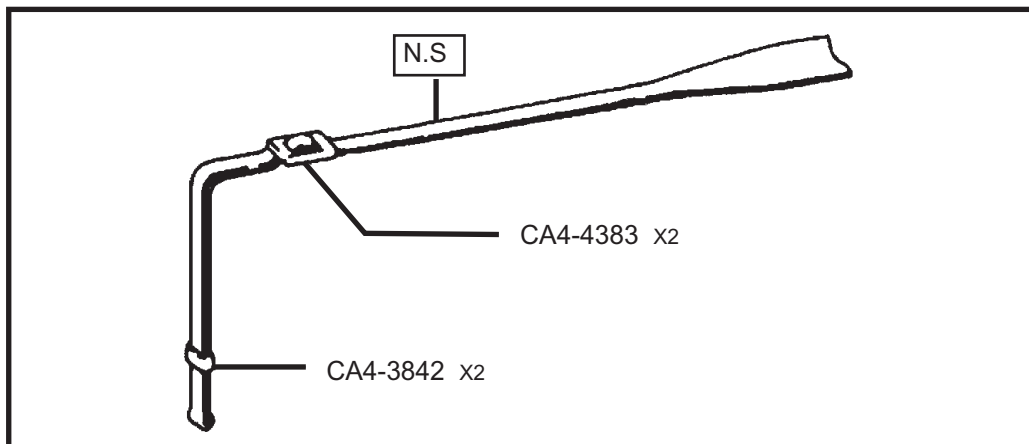

CANON INTERFACE CABLE IFC-450D6

REF.NO.C50-8081

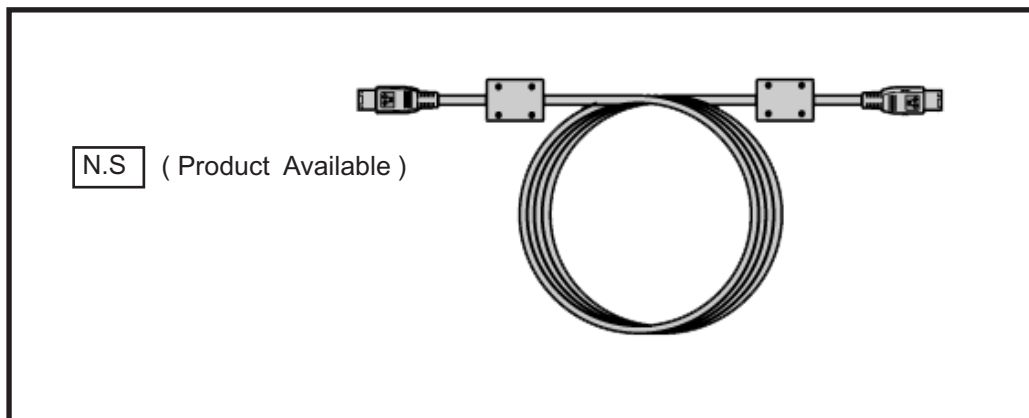

CANON Ni-MH PACK NP-E3

REF.NO.C50-8041,C50-8042

PG15

NEW	PARTS No.	CLASS	QTY	DESCRIPTION
	CA1-9411-000	F	2	SCREW
	CB3-0301-000	C	1	COVER, BAT TERMINAL
	CG2-0737-000	C	1	COVER ASS'Y, BATTERY

CANON NECK STRAP L4

REF.NO.C56-1731

NEW	PARTS No.	CLASS	QTY	DESCRIPTION
	CA4-3842-000	D	2	CLASP
	CA4-4383-000	D	2	LOOP

CANON DC COUPLER KIT DCK-E1

REF. NO. C50-8051

DC COUPLER DC-E1

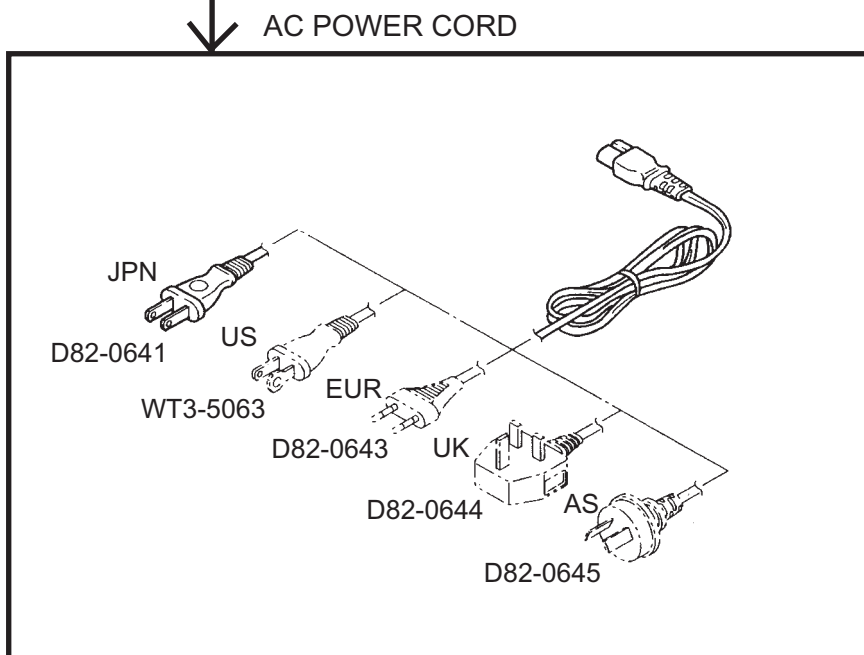
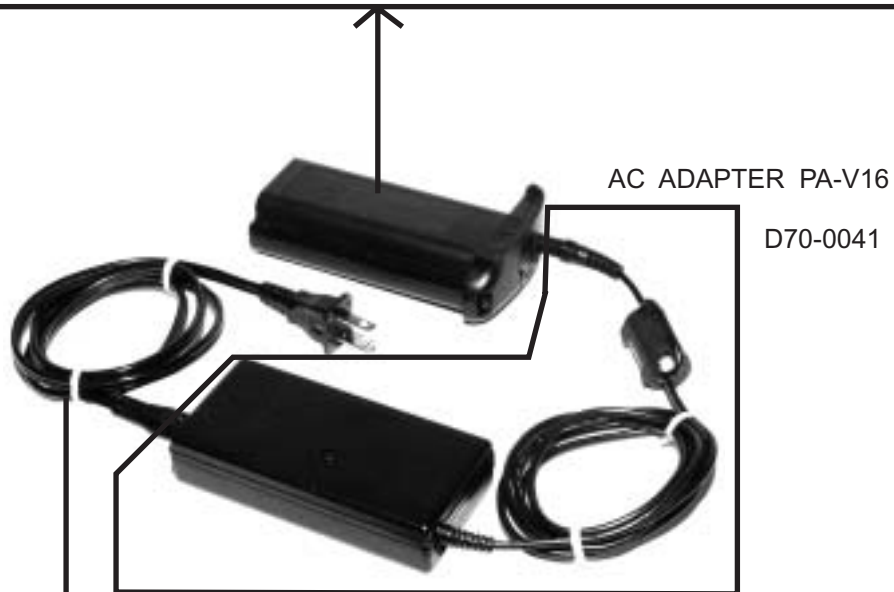
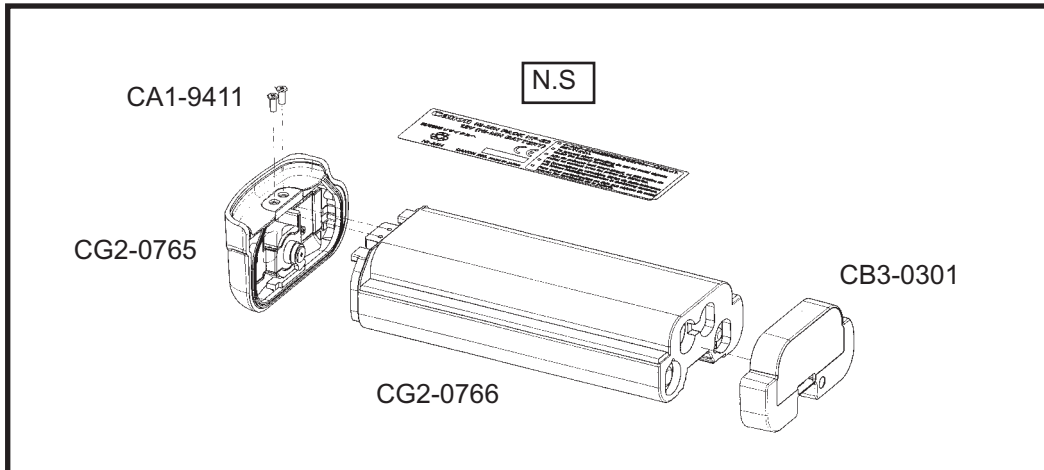

CANON DC COUPLER KIT DCK-E1

REF.NO.C12-6021

PG16

NEW	PARTS No.	CLASS	QTY	DESCRIPTION
	CA1-9411-000	F	2	SCREW, CROSS-RECESS, PH
	CB3-0301-000	C	1	COVER, BAT TERMINAL
	CG2-0765-000	C	1	COVER ASS'Y, BATTERY
	CG2-0766-000	C	1	PACK ASS'Y, AC
	D70-0041-000	C	1	AC ADAPTER PA-V16
	D82-0641-000	C	1	CORD, AC POWER (JPN)
	D82-0643-000	C	1	CORD, AC POWER (EUR)
	D82-0644-000	C	1	CORD, AC POWER (UK)
	D82-0645-000	C	1	CORD, AC POWER (AUST)
	WT3-5063-000	C	1	CORD, AC POWER (US)

ELECTRIC PARTSLIST

REF.NO.C50-8051

PG17

NEW	PARTS No.	CLASS	QTY	DESCRIPTION
	CH2-8028-000			LEAD WIRE
	CH2-8029-000			LEAD WIRE
	CH2-8031-000			LEAD WIRE
	CH2-8032-000			LEAD WIRE
	Y11-3402-000			LEAD WIRE BLACK
	Y11-3403-000			LEAD WIRE RED
	Y11-3704-000			LEAD WIRE PINK
	Y11-3714-000			LEAD WIRE GRAY
	Y11-3901-000			LEAD WIRE WHITE
	Y11-3902-000			LEAD WIRE BLACK
	Y11-3903-000			LEAD WIRE RED
	Y11-3906-000			LEAD WIRE ORANGE
	Y11-3907-000			LEAD WIRE YELLOW
	Y11-3914-000			LEAD WIRE GRAY
	Y11-5002-000			LEAD WIRE BLACK
	Y11-5004-000			LEAD WIRE PINK
	Y11-5007-000			LEAD WIRE YELLOW
	Y11-5011-000			LEAD WIRE BLUE

INDEX OF PARTS LIST

REF.NO.C12-6021 C50-8041,2
C56-1731,8051,61

NEW	PARTS No.	Page	NEW	PARTS No.	Page
	CA1-5074-000	6		CB1-9155-000	12
	CA1-5077-000 (XXX)	10		CB1-9168-000	3
	CA1-6504-040	9		CB1-9182-000	8
	CA1-7531-000	5		CB1-9183-000	8
	CA1-7606-000	12,13		CB1-9184-000	9
	CA1-7777-000	10		CB1-9186-000	9
	CA1-9007-000	6		CB1-9194-000	9
	CA1-9078-000 (XXX)	10		CB1-9195-000	3
	CA1-9079-000 (XXX)	10		CB1-9196-000	3
	CA1-9118-000	12		CB1-9198-000	9
	CA1-9119-000	12,13		CB1-9199-000 (020)	9
	CA1-9126-000	12		CB1-9201-000	9
	CA1-9168-000	9		CB1-9202-000	9
	CA1-9176-000	9,13		CB1-9203-000	9
	CA1-9245-000	10		CB1-9204-000	9
	CA1-9328-000	9		CB1-9206-000	9
	CA1-9402-000	3		CB1-9207-000	9
	CA1-9407-000	12		CB1-9209-000	9,13
	CA1-9415-000	12		CB1-9210-000	9,13
	CA1-9418-000	8		CB1-9211-000	9,13
	CA1-9422-000	9		CB1-9212-000	9,13
	CA4-5146-000	13		CB1-9213-000	9,13
	CA4-5147-000	13		CB1-9214-000	9,13
	CB1-2678-000	4		CB1-9215-000	9,13
	CB1-4236-000	10		CB1-9225-000	9
	CB1-4255-000	3		CB1-9262-000	10
	CB1-6761-000	9		CB1-9282-000	3
	CB1-6762-000	9		CB1-9285-000	10
	CB1-7706-000	6		CB1-9308-000	10
	CB1-7707-000	6		CB1-9309-000	10
	CB1-7756-000	6		CB1-9349-000	9
	CB1-7977-000	6		CB1-9353-000	6
	CB1-7982-000	3		CB1-9357-000	14
	CB1-8581-000	3		CB1-9360-000	8
	CB1-9119-000 (024)	10		CB1-9363-000	9
	CB1-9145-000	8		CB1-9367-000	3,12,13
	CB1-9149-000	12,13		CB1-9369-000	6
	CB1-9152-000	12		CB1-9373-000	3
	CB1-9153-000	12		CB1-9374-000	12,13
	CB1-9154-000	12		CB1-9379-000	8

INDEX OF PARTS LIST

REF.NO.C12-6021 C50-8041,2
C56-1731,8051,61

NEW	PARTS No.	Page	NEW	PARTS No.	Page
	CG2-0768-000	10		CY1-1280-000	10
	CG2-0788-000	6		CY3-1240-000	13
*	CG2-0850-000	6		CY3-1240-000 (XXX)	9
*	CG2-0872-000	5		CY3-1372-000	7
*	CG2-0874-000	9	*	CY3-1425-000	1
*	CG2-0875-000	11	*	CY3-1426-000	2
*	CG2-0878-000	5		WA4-6780-000	9
*	CG2-0887-000	6		X99-0583-000	12,13
*	CG2-0888-000	4		X99-0635-000	10
*	CG2-0889-000	4		X99-0689-000	14
*	CG2-0890-000	4		XA1-1200-959	5
*	CG2-0891-000	4		XA1-3140-189	10
*	CG2-0892-000	4		XA1-3170-307	10
*	CG2-0893-000	10		XA1-3170-457	9
*	CG2-0894-000	14		XA1-7140-307	5
*	CG2-0895-000	14		XA1-7170-167	4
*	CG2-0896-000	14		XA1-7170-207	1
*	CG2-0897-000	5		XA1-7170-257	4,6,11
*	CG2-0898-000	3		XA1-7170-307	1,5,6,8
*	CG2-0899-000	2		XA1-7170-357	2,4,5,10,11
*	CG2-0901-000	6		XA1-7170-359	10
*	CG2-0973-000	14		XA1-7170-407	4,6
*	CG2-0974-000	14		XA1-7170-457	1
*	CG2-0975-000	9		XA1-7170-507	3,5
*	CG2-0976-000	6		XA1-7170-607	6
*	CH1-8075-000	4		XA1-7170-707	1
*	CH1-8153-000	6		XA1-7200-507	5,6
*	CH1-8154-000	6		XA4-5170-357	7
	CH2-5285-000	9		XA4-8170-409	14
	CH2-5286-000	9		XA4-9140-307	14
	CH2-5287-000	9		XA4-9170-357	9
	CH2-5288-000	8		XA4-9170-409	12,13,14
	CH2-8002-000	11		XA4-9170-457	9
	CH5-2004-000	11		XA4-9170-507	9,12,13
	CH5-2006-000	11		XA4-9170-509	14
	CS2-5003-000 (XXX)	12,13		XA4-9170-707	8,9
	CS2-5020-000	10		XD1-1102-120	10
	CS2-7205-000	10		XD1-1102-121	10
	CS3-5021-000	8		XD1-1102-122	10
	CS3-6036-000	10		XD2-1100-132	9,13

INDEX OF PARTS LIST

REF.NO.C12-6021 C50-8041,2
C56-1731,8051,61

<u>NEW</u>	<u>PARTS No.</u>	<u>Page</u>	<u>NEW</u>	<u>PARTS No.</u>	<u>Page</u>
	XD2-1100-202	9,13			
	XG8-1100-581	12,13			
	YN2-9547-000	14			

DATA VERIFICATION KIT DVK-E1



CH9-1030-000

CH9-1028-000

CH9-1029-000

PARTS LIST

REF.NO.C50-2352

PG1

NEW	PARTS No.	CLASS	QTY	DESCRIPTION
*	CH9-1028-000	C	1	IC CARD READER/WRITER PC-KC5700
*	CH9-1029-000	C	1	IC CARD, DV-E1
*	CH9-1030-000	C	1	EOS DATA VERIFICATION DISK V1.0 J/E