

Canon

**EF 85mm 1:1.2 L
REF.NO.C21-7272**

**PARTS
CATALOG**

CANON LENS EF85 mm 1:1.2 L

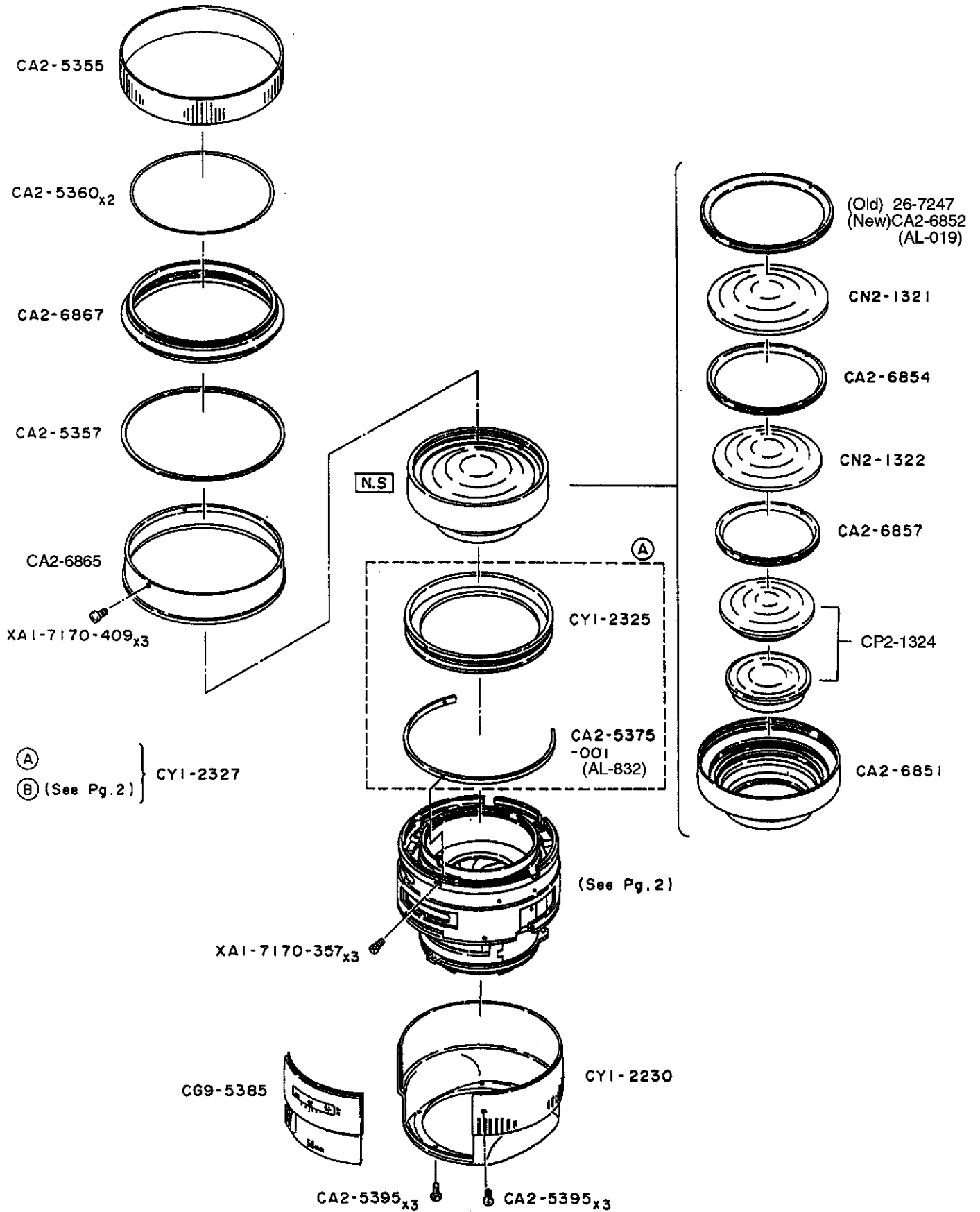

CANON LENS EF 85 mm 1:1.2 L

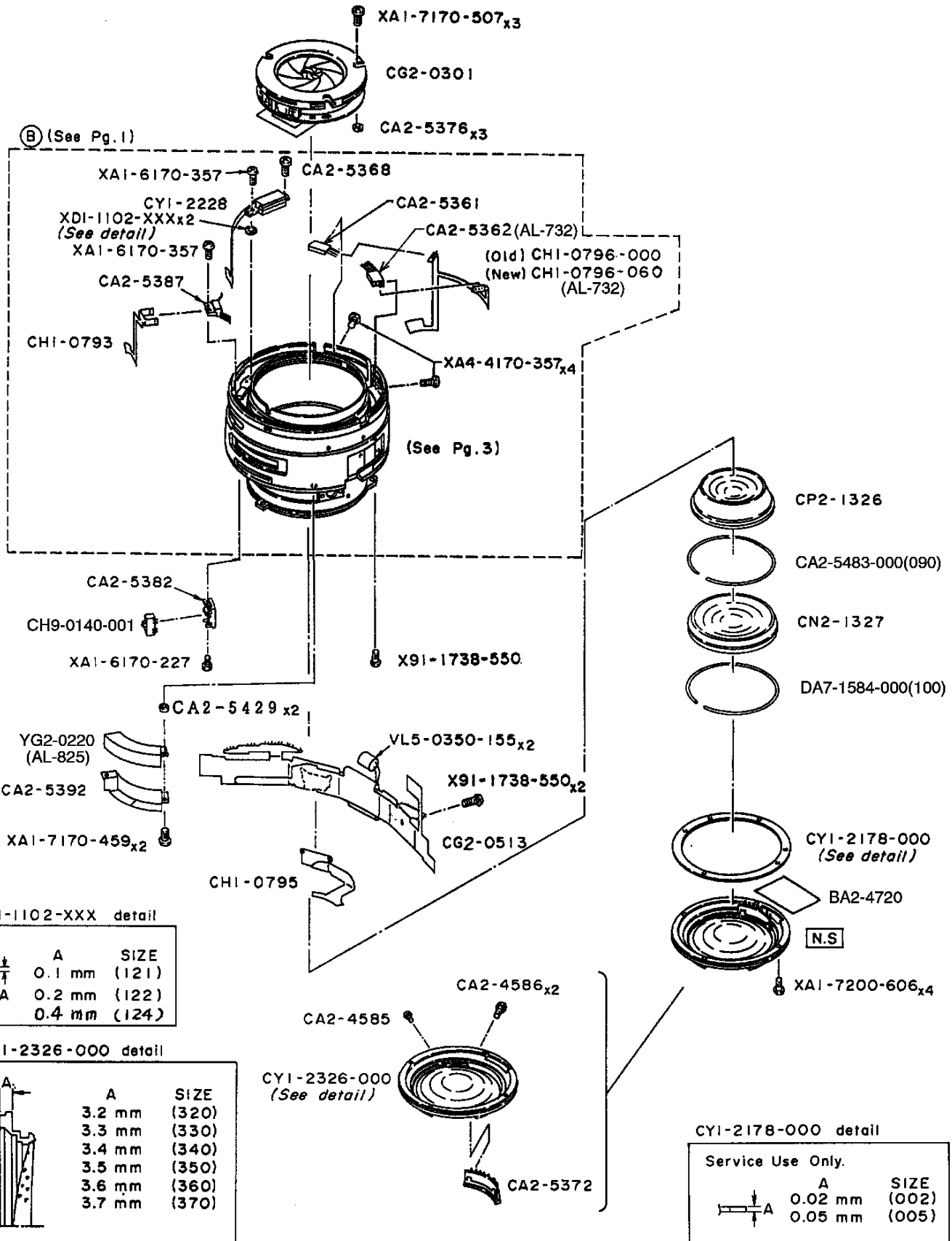

XDI-1102-XXX detail

A	SIZE
0.1 mm	(121)
0.2 mm	(122)
0.4 mm	(124)

CYI-2326-000 detail

A	SIZE
3.2 mm	(320)
3.3 mm	(330)
3.4 mm	(340)
3.5 mm	(350)
3.6 mm	(360)
3.7 mm	(370)

CYI-2178-000 detail

Service Use Only.

A	SIZE
0.02 mm	(002)
0.05 mm	(005)

PARTS LIST

REF.No.C21-7272

NEW	PART.NO.	CLASS	QTY	DESCRIPTION	PAGE
	26-7247-000	D	1	ASSEMBLY COLLAR (OLD)	1
	BA2-4720-000	E	1	SEAL, INSULATING	2
	CA2-4585-000	E	1	SCREW, MOUNT STOPPER	2
	CA2-4586-000	E	2	SCREW	2
	CA2-5341-000		36	BALL, STEEL	3
	CA2-5351-000	E	1	RACE, BALL (1)	3
	CA2-5352-000	E	1	COLLAR, ASSEMBLY	3
	CA2-5353-000	E	1	RACE, BALL (2)	3
	CA2-5355-000	D	1	RING, RUBBER	1
	CA2-5357-000	D	1	RING, L INDICATOR	1
	CA2-5360-000	E	2	WASHER, DUST SHIELD	1
	CA2-5361-000	D	1	CONTACT, PULSE BOARD	2
	CA2-5362-000	D	1	CONTACT, PULSE BOARD	2
	CA2-5368-000	E	1	SCREW	2
	CA2-5372-000	D	1	CONTACT ASS'Y	2
	CA2-5375-001	E	1	GUIDE, PULSE BOARD HOLDER	1
	CA2-5376-000	E	3	WASHER	2
	CA2-5382-000	D	1	HOLDER, SWITCH	2
	CA2-5387-000	D	1	CONTACT, FOCUSING LIMIT	2
	CA2-5392-000	E	1	COVER, DC/DC CONVERTOR	2
	CA2-5394-000 (010)	E	1	WASHER, ADJUSTING	3
	CA2-5394-000 (015)	E	1	WASHER, ADJUSTING	3
	CA2-5395-000	E	6	SCREW, CROSS-RECESS, PH	1
	CA2-5429-000	E	2	SPACER, DC/DC	2
	CA2-5483-000 (090)	E	1	RING, SNAP	2
	CA2-6851-000	E	1	BARREL, LENS	1
	CA2-6852-000	D	1	COLLAR, ASSEMBLY (NEW)	1
	CA2-6854-000	E	1	COLLAR, ASSEMBLY	1
	CA2-6857-000	E	1	COLLAR, ASSEMBLY	1
	CA2-6865-000	D	1	RING, MANUAL	1
	CA2-6867-000	D	1	RING, NAME	1
	CG2-0301-000	D	1	POWER DIAPHRAGM UNIT	2
	CG2-0513-000	D	1	MAIN FLEX ASS'Y	2
	CG9-5385-000	D	1	FOCUSING INDEX UNIT	1
	CH1-0793-000	E	1	FLEX, CONNECTING	2
	CH1-0795-000	E	1	FLEX, CONNECTING (MOUNT)	2
	CH1-0796-000	E	1	FLEX, CONNECTING (OLD)	2
	CH1-0796-060	E	1	FLEX, CONNECTING (NEW)	2
	CH9-0140-001	E	1	SWITCH, SLIDE	2
	CN2-1321-000	C	1	LENS, G1	1
	CN2-1322-000	E	1	LENS, G2	1
	CN2-1327-000	E	1	LENS, G7	2
	CP2-1324-000	E	1	LENS, G3/4	1
	CP2-1326-000	E	1	LENS, G5/6	2
	CY1-2178-000 (002)	E	1	WASHER, MOUNT	2
	CY1-2178-000 (005)	E	1	WASHER, MOUNT	2
	CY1-2228-000	D	1	MANUAL FOCUS SENSOR UNIT	2
	CY1-2230-000	D	1	COVER, MAIN	1
	CY1-2325-000	D	1	RING, MANUAL FOCUSING	1
	CY1-2326-000 (320)	D	1	MOUNT, LENS	2
	CY1-2326-000 (330)	D	1	MOUNT, LENS	2
	CY1-2326-000 (340)	D	1	MOUNT, LENS	2
	CY1-2326-000 (350)	D	1	MOUNT, LENS	2
	CY1-2326-000 (360)	D	1	MOUNT, LENS	2
	CY1-2326-000 (370)	D	1	MOUNT, LENS	2

PARTS LIST

REF.No.C21-7272

NEW	PART.NO.	CLASS	QTY	DESCRIPTION	PAGE
	CY1-2327-000	D	1	FOCUSING UNIT	1
	DA7-1584-000 (100)	E	1	RING, SNAP	2
	VL5-0350-155	E	2	COIL	2
	X91-1738-550		3	SCREW, CROSS-RECESS, PH	2
	XA1-6170-227		1	SCREW, CROSS-RECESS, PH	2
	XA1-6170-357		2	SCREW, PH 1.7X3.5	2
	XA1-7170-357		3	SCREW, CROSS-RECESS, PH	1
	XA1-7170-409		3	SCREW, CROSS-RECESS, PH	1
	XA1-7170-459		2	SCREW, CROSS-RECESS, PH	2
	XA1-7170-507		3	SCREW, CROSS-RECESS, PH	3
	XA1-7200-606		4	SCREW, CROSS-RECESS, PH	2
	XA4-4170-357		4	SCREW, CROSS-RECESS, PH	2
	XD1-1102-121	N		WASHER	2
	XD1-1102-122	N		WASHER	2
	XD1-1102-124	N		WASHER	2
	XG8-1100-012		36	BALL, STEEL	3
	Y11-3902-000			LEAD (BLACK)	
	Y11-3903-000			LEAD (RED)	
	Y11-3907-000			LEAD (YELLOW)	
	Y11-5002-000			LEAD (BLACK)	
	Y11-5003-000			LEAD (RED)	
	YG2-0220-000	D	1	CONVERTER, DC/DC	2

CANON LENS EF85 mm 1:1.2 L

REF. NO. C21-7272

